



Lewis Acid Site "Deactivated"
Zirconia-Based Columns for HPLC

Includes
NEW
Quick-Start
Guide!

ZirChrom®-EZ & ZirChrom®-MS Method Development Guide

Column Use Tips

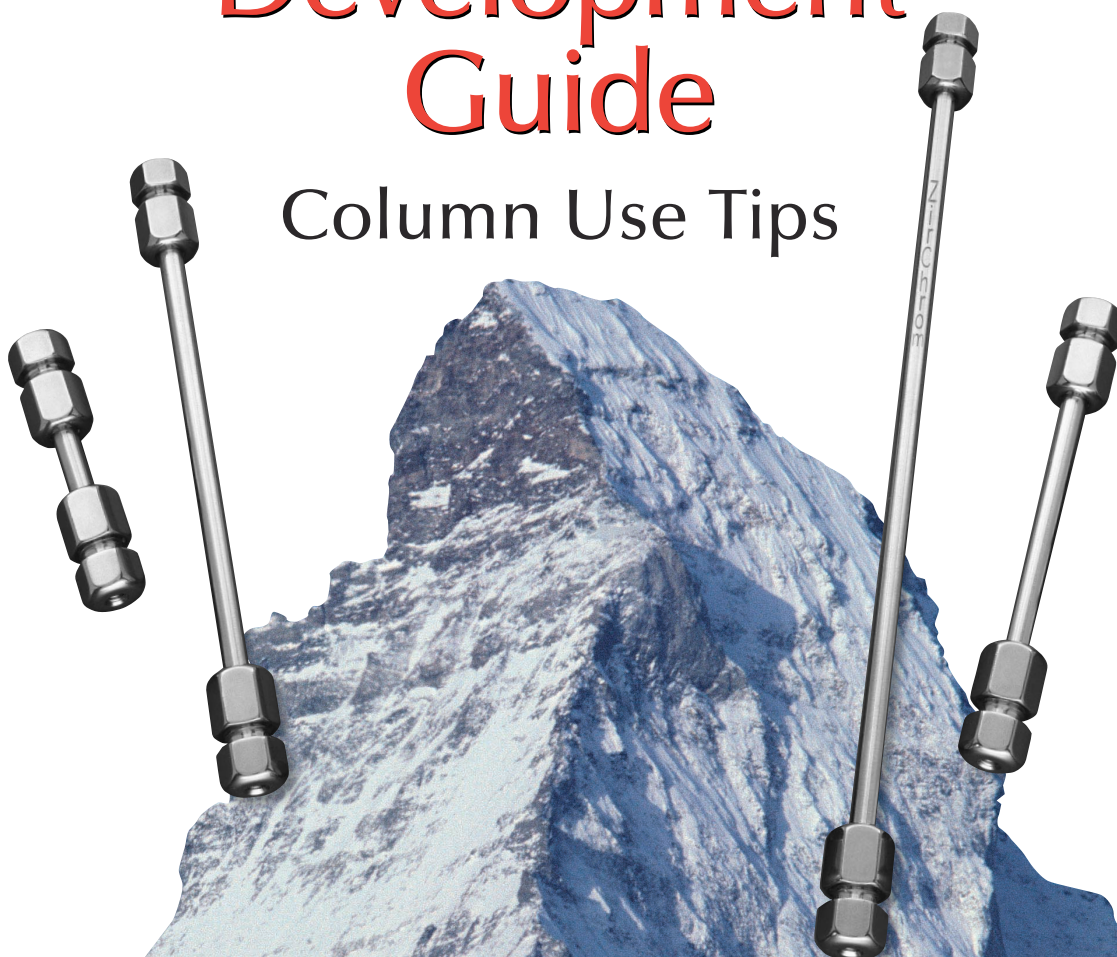

tel 1-866-STABLE-1 / fax 1-763-421-2319 / www.zirchrom.com

PART I / QUICK-START GUIDE

Start-up Procedure ▶ 2

Installing the Column

Validating Column Performance

Mobile Phase pH

Equilibrating the Column

Use with LC/MS

ZirChrom®-EZ & ZirChrom®-MS ▶ 4

General Use Tips

Column Maintenance ▶ 5

Cleaning/Regeneration Procedure

Storage Conditions

PART II

High Performance Reversed-Phase Chromatography ▶ 7

General Method Development Guidelines ▶ 8

1. Mobile Phase Composition

2. Buffer Composition

3. pH Selection

4. Analyte-Specific Guidelines

PART III

Other Products and Services ▶ 23

Please read this guide carefully before using your new column.

INTRODUCTION

Thank you for purchasing a ZirChrom® HPLC column. Due to its unique characteristics—namely that its packing material is zirconia-based rather than silica-based, we strongly recommend that you read this guide before using your column. Method development with zirconia-based columns involves different steps than those used with silica- or polymer-based columns. In this guide, we have outlined those steps and different chemistries. If at any time you have questions about your column or method development, please call our technical support line at [1-866-STABLE-1 \(1-866-782-2531\)](tel:1-866-STABLE-1) to speak to one of our on-staff chemists, or email us at support@zirchrom.com. We will be happy to help you.

Note: This guide is for ZirChrom®-EZ and ZirChrom®-MS only. Alternate guides are available for other ZirChrom columns.



PART I / QUICK-START GUIDE

Start-up Procedure

This section contains start-up guidelines to successfully install and equilibrate your ZirChrom zirconia-based column.

INSTALLING THE COLUMN

Connect the column with the direction of the flow arrow on the label pointing **toward** the detector. To maximize the life of your column, we recommend using a guard column. (Refer to your instrument's manual for information on the proper installation of columns.)

VALIDATING COLUMN PERFORMANCE

Upon receipt of your column, duplicate the results on the Column Evaluation document enclosed with this guide. You should be able to achieve a plate count consistent with the operating conditions listed for your column. Be sure to inject roughly the same amount of material indicated on the chromatogram. Repeat this test periodically to track column performance over time.

Slight variations may be obtained on two different HPLC systems due to system electronics, plumbing, operating environment, reagent quality, column condition and operator technique.

MOBILE PHASE PH

ZirChrom[®]-EZ and -MS are stable in the mobile phase pH range of 1-10. **

**Stable up to pH 12 with the inclusion of EDTPA [Ethylenediamine-N,N,N',N'-tetra(methyl-enephosphonic acid)].

EQUILIBRATING THE COLUMN

1. Equilibrate your column when it is installed for the first time. Verify that your mobile phase is miscible in the shipping solvent, which is acetonitrile. Always re-equilibrate the column with your mobile phase before using it again after it has been stored.
2. The column can be used with any common organic modifier including acetonitrile, methanol, tetrahydrofuran or isopropanol.

3. The column temperature may be set at any temperature **up to 50 °C**.
4. Purge the column with at least 10 column volumes of your mobile phase or until you achieve a stable baseline.

USE WITH LC/MS

We recommend running at least two 30-minute gradients of 10-90% acetonitrile/water (weak to strong) to condition your column before use with your HPLC/MS system.



ZirChrom®-EZ & ZirChrom®-MS

General Use Tips

1. Upon receipt, we suggest you duplicate the results shown on the enclosed chromatogram. You should be able to achieve a plate count of at least 100,000 N/meter for toluene under the operating conditions given on the chromatogram (for 3 micron materials). Be sure to inject roughly the same amount of material as indicated in the chromatogram.
2. The column can be used with any common organic modifier (i.e., acetonitrile, methanol, tetrahydrofuran or isopropanol) but we find that acetonitrile typically gives better plate counts. ZirChrom®-EZ is less hydrophobic than common silica-based supports. For simple non-ionic compounds on ZirChrom®-EZ, we recommend that you use about 10% less organic modifier to obtain roughly the same retention as you would on a typical C8 or C18 silica-based column. ZirChrom®-MS has about the same hydrophobicity as common silica based supports. For simple non-ionic compounds on ZirChrom®-MS, we recommend that you try the same level of organic modifier as you would on a typical C8 or C18 silica based support.
3. When running ionizable compounds on any stationary phase a buffer should be used (see ZirChrom Buffer Wizard at www.zirchrom.com). Our first choice for both acidic and basic analytes is a 10-25 mM pH 5.0 ammonium acetate buffer. However, these columns are stable from pH 1 to pH 10** and a variety of buffers may be employed within this pH range. At the present time, we do not recommend the use of high concentrations (>100 mM) of fluoride, carboxylic acid (acetate, citrate, bicarbonate/carbonate) buffers and salts. Also, phosphate concentrations in excess of 25 mM will have a detrimental effect on the column.
4. We recommend the following precautions regarding day-to-day operation of the column:
 - Always check the solubility of the buffer being used when mixing with organic mobile phases using an LC pump.
 - Avoid fluoride containing buffers below pH 4.
 - Avoid injecting metal chelating compounds or proteins.

Caution: Do not use PEEK tubing with tetrahydrofuran-rich mobile phases.

***Stable up to pH 12 with the inclusion of EDTPA.*

Column Maintenance

To maximize the life of this ultra-durable column, we recommend the following:

- ✓ **Always use a guard column.**
- ✓ Clean up samples before injection (either filtering to remove particulates or solid phase extraction techniques).
- ✓ Use HPLC grade solvents and filter all solutions before use.
- ✓ Minimize pressure surges.
- ✓ Use an in-line filter (0.5 micron) in front of the column to catch large particles.
- ✓ Routinely flush the column with a strong solvent to elute retained materials off of the phase.
- ✓ Flush all buffers and salts from the column before storage.

Do not use PEEK tubing with mobile phases rich in tetrahydrofuran (> 10%).

Please refer to your column's Care and Use sheet for specific instructions.

Cleaning/Regeneration Procedure

To remove substances that may have fouled the column, use the following three-step cleaning protocol (**IMPORTANT*—During these steps, you should remove your detector from the flow path to protect it from aggressive cleaning conditions*):

1. Flush column with a mixture of 20/80 acetonitrile/pH 10 ammonium hydroxide for 50 column volumes at ambient temperature. Follow base wash with 10 column volumes of water at ambient temperature.
2. Flush column with a mixture of 20/80 acetonitrile/0.1 M nitric acid for 50 column volumes at ambient temperature. Follow acid wash with 10 column volumes of water at ambient temperature.
3. Flush column with 100% organic solvent for 20 column volumes at ambient temperature. Methanol, acetonitrile, isopropanol, and tetrahydrofuran are all adequate solvents.

Storage Conditions

Do not store your column in phosphate buffer.

Refer to your column's Care and Use sheet, but in general, ZirChrom® zirconia-based columns should be flushed with 50/50 organic modifier/ water for 30 column volumes prior to storage overnight. For long-term storage, flush the column with pH 10 ammonium hydroxide for 10 column volumes, followed by 30 column volumes of 50/50 organic modifier/water.

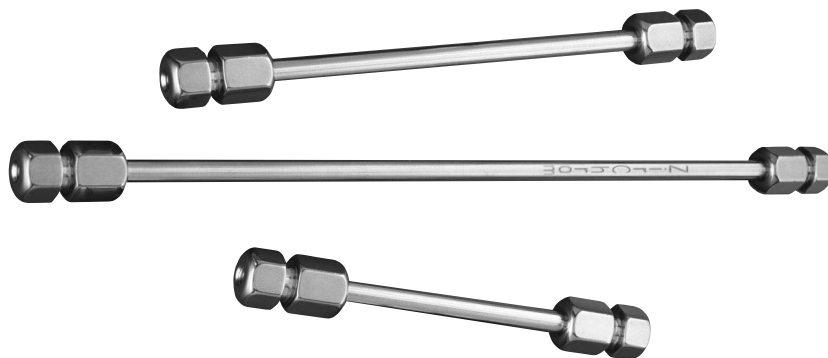

PART II

High-Performance Reversed-Phase Chromatography

Reversed-phase separations employ a polar eluent and a nonpolar (hydrophobic) stationary phase. The hydrophobic layer (or phase) is bonded or coated onto a rigid support that can withstand the high pressures commonly used in HPLC. Until recently, about 80% of all HPLC methods specified silica-based stationary phases. However, silica does have some limitations:

- Silica is readily soluble in aqueous solutions at pHs higher than 7.5.
- Bonded silicas may briefly resist chemical attack at higher pH ranges—but silica exposed through the coating is attacked and progressively broken down.
- Many silica-based bonding chemistries are not stable at high temperatures ($> 40\text{ }^{\circ}\text{C}$).
- Hydrolysis of the siloxane bond at low pH, resulting in stationary phase “bleed”, leads to retention time irreproducibility and high background noise for LC/MS applications.

Polymeric column packings frequently exhibit shrinking or swelling as mobile phase modifier composition changes. They are inherently less efficient than silica and zirconia based particles for most separations.

Zirconia-based columns are revolutionary HPLC phases. Zirconia particles are mechanically stable, and have a porous structure similar to that of silica. However, zirconia's main advantage over silica is that it is very stable in a wide range of eluent pH; indeed the ZirChrom[®]-EZ and ZirChrom[®]-MS phases are stable over the pH range of 1-10.

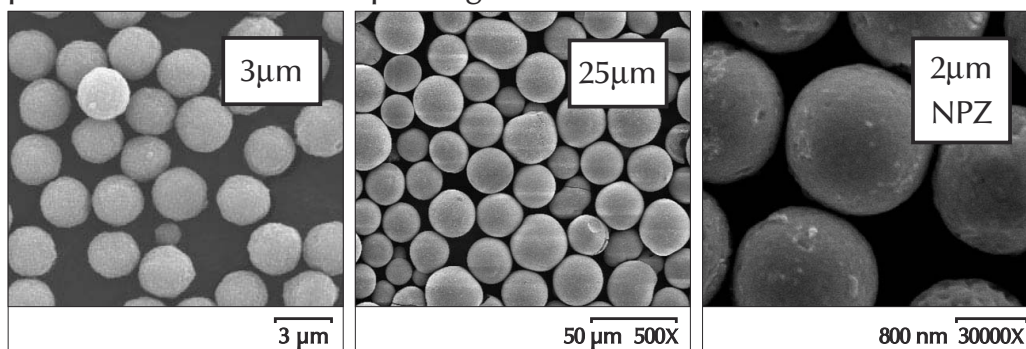

Figure 1. Porous and Nonporous Zirconia Particles

General Method Development Guidelines for ZirChrom[®]-EZ and ZirChrom[®]-MS

Zirconia-based phases are much closer to silica-based phases in behavior than are polymeric and carbon-based phases, but yet significantly differ from silica in several important ways. The method development differences between silica-based and zirconia-based reverse-phase method development can be illustrated as follows:

Operational *Similarities* for Silica and ZirChrom[®]-EZ / ZirChrom[®]-MS

- k' increases with molecular hydrophobicity (-CH₃, -CH₂-, phenyl, etc.).
- Similar elution sequence of non-electrolytes.
- k' decreases 2-fold per 10% increase in volume % organic modifier.
- Log k' versus % organic modifier is linear.
- k' decreases as temperature is increased (3-fold/50 °C).
- Solvent strength: tetrahydrofuran > acetonitrile > methanol.
- ZirChrom[®]-EZ and ZirChrom[®]-MS are very efficient (N > 100,000 plates/meter) hydrophobic, inorganic-based stationary phases.

Operational *Differences* in Silica and ZirChrom[®]-EZ / ZirChrom[®]-MS

- ZirChrom[®]-EZ and ZirChrom[®]-MS offer improved peak shape, efficiency, and different chromatographic selectivity for basic drugs compared to bonded phase C18.
- Cations are typically more retained and *sometimes much more retained* on ZirChrom[®]-EZ and -MS than on silica phases.
- Elution sequence of anions and cations can be very different on zirconia and silica at neutral pH.
- Operation in a pH range where analytes are ionized creates mixed-mode reversed-phase/ion-exchange possibilities.
- Lewis base modifier at mid-range pH creates mixed-mode reverse-phase/ion-exchange possibilities.
- Less organic modifier may be needed (depending on analyte), especially with ZirChrom[®]-EZ.
- k' of amine containing analytes DECREASES at pH above pKa!

note: k' = retention factor

1. Mobile Phase Composition

ZirChrom® columns can be used with many common organic modifiers, including acetonitrile, methanol, tetrahydrofuran and isopropanol. For mobile phase optimization, follow these steps:

- Define the best type of modifier: acetonitrile, methanol or tetrahydrofuran. Keep in mind that the order of eluent strength is tetrahydrofuran > acetonitrile > methanol.
- Define optimum solvent strength so that k' for all solutes is in the range of 1-20.
- Perform stepwise isocratic study in 20% steps starting at 100% organic.
- Perform gradient determination of % organic.

For method developers using ZirChrom® columns acetonitrile is usually the eluent of choice due to its superior UV absorbance and low viscosity.

2. Buffer Composition

Obtaining satisfactory peak shape for your analytes requires the proper choice of a mobile phase buffer. Buffers improve peak shape of basic compounds and can help modify the band spacing (or selectivity) and retention of acidic or basic compounds. We strongly recommend 10 - 20 mM of an ammonium salt of your choice as a starting buffer (i.e. acetate, formate, carbonate, or phosphate salts) for electrolyte solutes. Further considerations for the proper choice of a buffer system and the manipulation of buffers as a method development tool are given below in the section method development for ionizable compounds.

3. pH Selection

Because ZirChrom®-EZ and ZirChrom®-MS are ultra-stable at low or high pH (pH 1-10), they are ideal for the following:

- Ionizable compounds
- Improving peak shape of acidic or basic compounds
- Changing selectivity or retention of acidic or basic compounds

For more information on how pH can affect method development on basic analytes (see page 14).

4. Analyte-Specific Guidelines

Method Development for Nonelectrolytes

ZirChrom®-EZ and ZirChrom®-MS exhibit reversed-phase characteristics similar to other zirconia- and silica-based reversed-phases. Figure 2 shows that as the volume of organic modifier in the mobile phases is increased, the retention for simple non-electrolytes decreases. For any nonelectrolyte analyte at neutral pH (e.g. ester, ether, alkane, alkene, alkyne, amides, alcohols, etc.) which is not a carboxylic acid or amine, you should choose the eluent just as you would for a Type A or B silica-based phase. For ZirChrom®-EZ we suggest that you use about 10% less organic modifier than you would with a silica-based phase. If you would normally start method development with 80% acetonitrile on a typical ODS phase we suggest you use 70% acetonitrile on ZirChrom®-EZ. This will put the retention factor in the same range as you would observe on a silica-based phase. If in normal method development you would change the strong solvent by 5% to either increase or decrease retention we suggest you make the same approximate change in composition using zirconia-based phases.

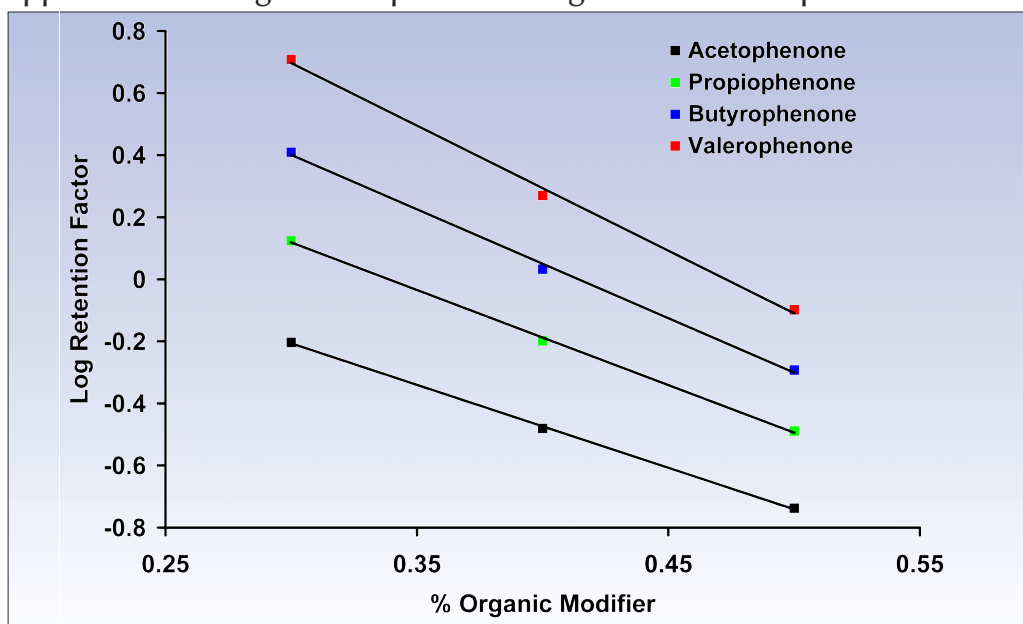

Figure 2. Plot of $\log k'$ versus volume fraction of organic modifier in the mobile phase for a homolog series of alkylphenones. LC Conditions: Column, 50 mm x 4.6 mm i.d. ZirChrom®-EZ (part# EZ01-0546); Mobile phase, acetonitrile/water mixture as indicated; Flow rate, 2.0 ml/min.; Temperature, 35 °C; Injection volume, 5 μ l; Detection at 254 nm.

The retention characteristics for ZirChrom[®]-MS are similar to bonded silica phases for **non-electrolytes** and you may use the same amount of organic modifier to obtain retention similar to silica-based reversed-phases. The ZirChrom[®]-EZ phase has about half the retention of ZirChrom[®]-MS.

The chromatographic selectivity of ZirChrom[®]-EZ and ZirChrom[®]-MS for **non-electrolytes** will be similar to ODS and phenyl type bonded phases on silica. Figure 3 shows that substituents which cause an increase in retention on silica phases cause an increase in retention of zirconia, and uncharged substituents that decrease retention (e.g. OH, NO₂, CHO, etc.) on silica also cause a decrease in retention on zirconia phases.

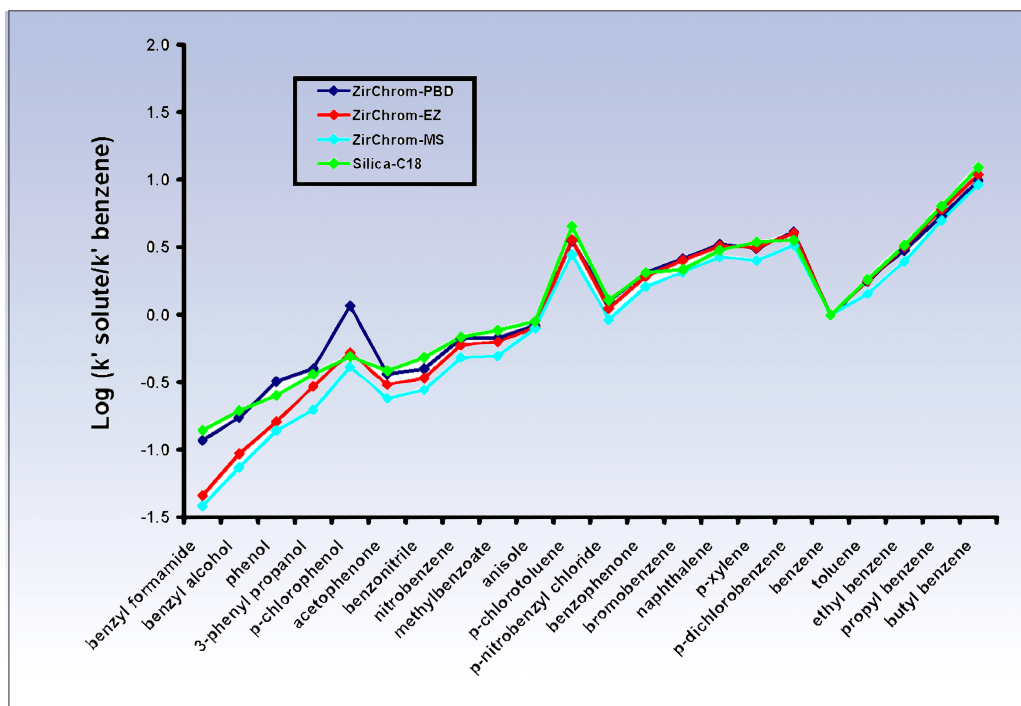

Figure 3. Retention of several non-electrolyte solutes on ZirChrom[®]-PBD, ZirChrom[®]-EZ, ZirChrom[®]-MS, and silica-C18 phases.

LC Conditions: Columns, 50 mm x 4.6 mm i.d.; Mobile phase, 40/60 acetonitrile/water; Flow rate, 1.0 ml/min.; Injection volume, 5 μ l; Temperature, 30 $^{\circ}$ C; Detection at 254 nm.



Method Development for Ionizable Analytes

In considering method development strategies for ionizable analytes using the ZirChrom®-EZ or ZirChrom®-MS column, it is important to understand that the surface chemistry of a “deactivated” zirconia-based reversed-phase column is significantly different from the more common bonded silica phases. The most practically significant difference between the materials is the amount of charged sites on the particle surface that can contribute to electrostatic interactions between the analyte and the particle surface.

Figure 4 shows the two dominant features of the surface of a typical ODS phase; namely the hydrophobic bonded octadecylsilane (C18) chains, and the silanol groups whose charge state is a function of the mobile phase pH.

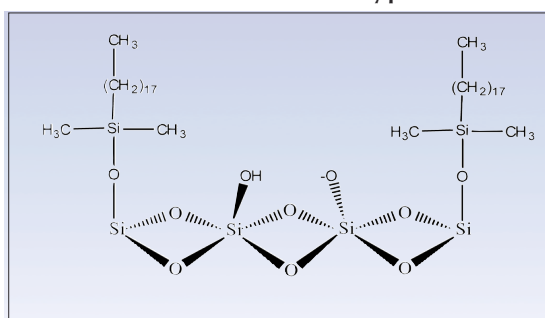

Figure 4. Schematic of the surface of a typical ODS phase. The two dominant features are hydrophobic C18 chains and ionizable silanol groups.

In contrast to the silica surface shown in Figure 4, Figure 5 shows the two dominant features of the surface of the “deactivated” zirconia-based phase; namely the highly crosslinked, hydrophobic polybutadiene polymer, and the negatively charged EDTPA (Ethylenediamine-N,N,N'N'-tetra(methylenephosphonic) acid) molecules which chelate the zirconia surface resulting in deactivation of available Lewis acid sites. Both of the stationary

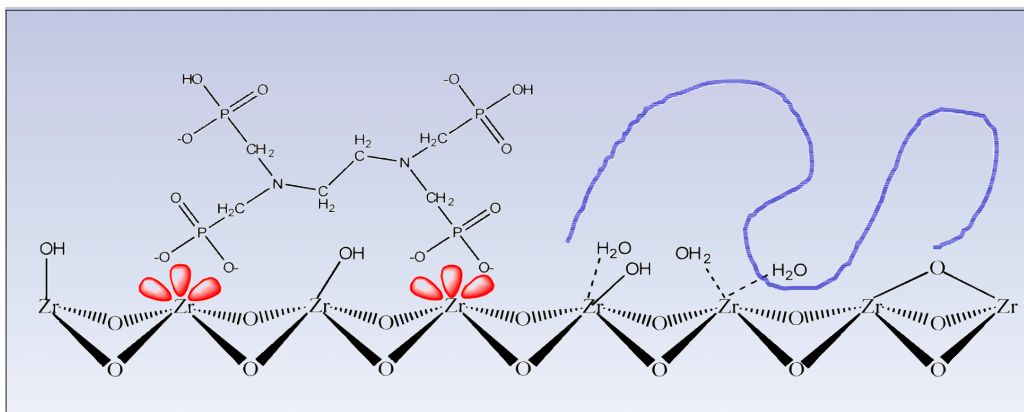
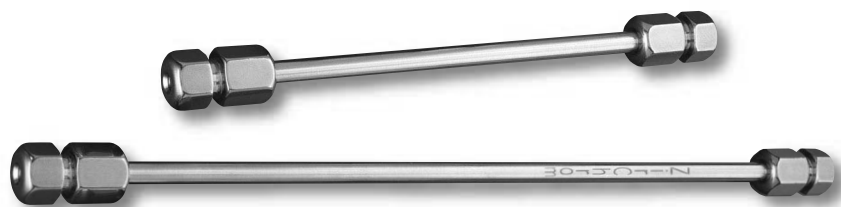

Figure 5. Schematic of the surface of ZirChrom®-EZ / ZirChrom®-MS. The two dominant features are hydrophobic polybutadiene polymer (depicted in blue), and negatively charged, immobilized EDTPA groups.

phases depicted in Figures 4 and 5 exhibit reversed-phase characteristics due to hydrophobic interactions with either the the bonded C18 ligands (ODS) or the crosslinked polybutadiene network (ZirChrom[®]-EZ / ZirChrom[®]-MS). Similarly, both materials also exhibit ion-exchange characteristics through interactions between ionizable analytes and either deprotonated silanol groups (ODS), or the negatively charged EDTPA immobilized on the surface of ZirChrom[®]-EZ / ZirChrom[®]-MS. While the two materials are similar by this comparison, they are dramatically different in that the contribution of the ion-exchange interaction in the retention of an analyte on ZirChrom[®]-EZ / ZirChrom[®]-MS will be much greater than is typically observed on ODS phases. From a method development perspective, this is actually a benefit in that the chemical differences between these phases often results in quite different chromatographic selectivity for ionizable analytes on ZirChrom[®]-EZ / ZirChrom[®]-MS compared to typical ODS phases (see Figure 9).

The other chromatographically significant feature of the ZirChrom[®]-EZ and ZirChrom[®]-MS phases is the deactivation of the surface Lewis acid sites. In Figure 5 the Lewis acid sites are depicted by the red, empty d-orbitals of surface zirconia atoms, indicating that they are free to interact with electron-donating Lewis bases in the mobile phase, whether they are present as mobile phase additives or analyte molecules. This permanent deactivation of the Lewis acid sites means that the surface chemistry of ZirChrom[®]-EZ and ZirChrom[®]-MS is only a function of the pH of the mobile phase, and is not sensitive to the type of Lewis base modifier that is used to buffer the mobile phase pH. The deactivation of the surface also means that non-volatile buffers such as phosphate are not required for good chromatography of Lewis base analytes, such as carboxylic acids, as they are required on other zirconia-based reversed-phase supports (ZirChrom[®]-PBD, ZirChrom[®]-PS, ZirChrom[®]-CARB and Diamondbond[®]-C18).



Method Development for Basic (Cationic) Analytes

In the method development process for ionizable analytes on zirconia-based phases, one must understand that zirconia's surface contributes significantly to the total retention of the analyte through electrostatic interactions between the analyte and the surface. These electrostatic interactions are in addition to the reversed-phase interactions that take place in RPLC between the analyte and the hydrophobic stationary phase. The extent to which the zirconia surface contributes to the retention of the analyte is determined by two principal factors:

1. The pH of the mobile phase affects both the zirconia's surface charge and the charge state of the analyte.
2. The pKa of the analyte.

The effects of the pH of the mobile phase on the surface charge on zirconia and silica are depicted in Figures 6 and 7. Figure 6 shows experimental data that indicate the effect of mobile phase pH on the negative charge of the ZirChrom®-EZ surface by measuring the retention of a permanently positively charge quaternary amine, benzyltrimethylammonium ion, in mobile phases buffered at different pHs. From these data it is clear that as the mobile phase pH is raised, the negative charge on the surface is increased resulting in increased retention of the quaternary amine. Figure 7 depicts a generalized theoretical effect of mobile phase pH on the surface charge state of silica. While the general trend of the deprotonation of surface silanols with increasing mobile phase pH is observed with all silica materials, the recent work of Neue and coworkers (Mendez, A.; Bosch, E.; Roses, M.; Neue, U. D. "Comparison of the acidity of residual silanol groups in several liquid chromatography columns." *Journal of Chromatography, A* 2003, 986, 33-44) has shown that the range in pH where ionization of the silanols occurs is heavily dependent upon the type and origin of the substrate itself.



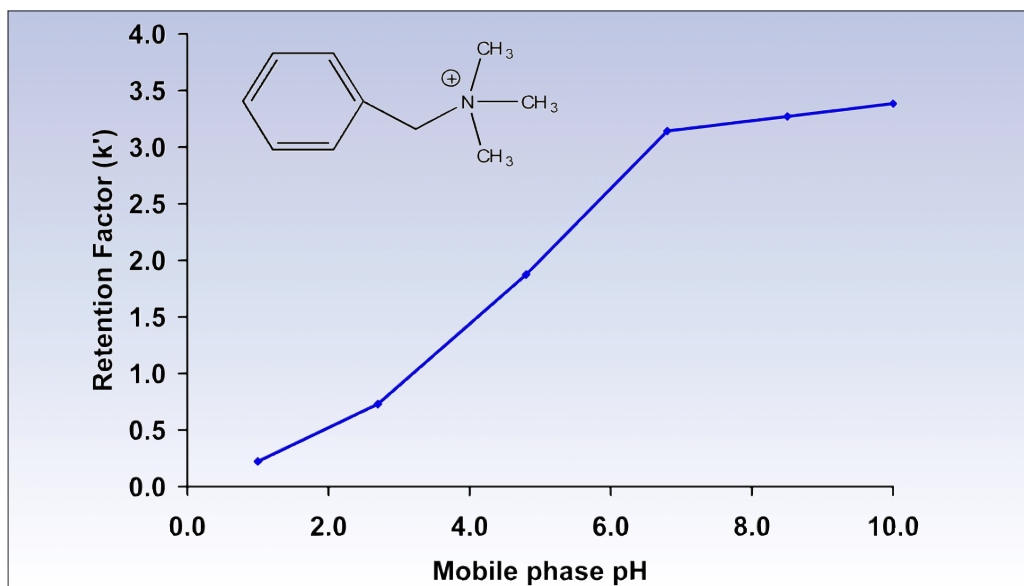

Figure 6. Retention of a permanently positively charged amine is affected by the mobile phase pH. LC Conditions: Column, 50 mm x 4.6 mm i.d. ZirChrom®-EZ (part# EZ01-0546); Mobile phase, 10mM of a buffer appropriate for the indicated pH, 100mM NaCl; Flow rate, 2.0 ml/min.; Temperature, 35 °C; Injection volume, 5 μ l; Detection at 254 nm.

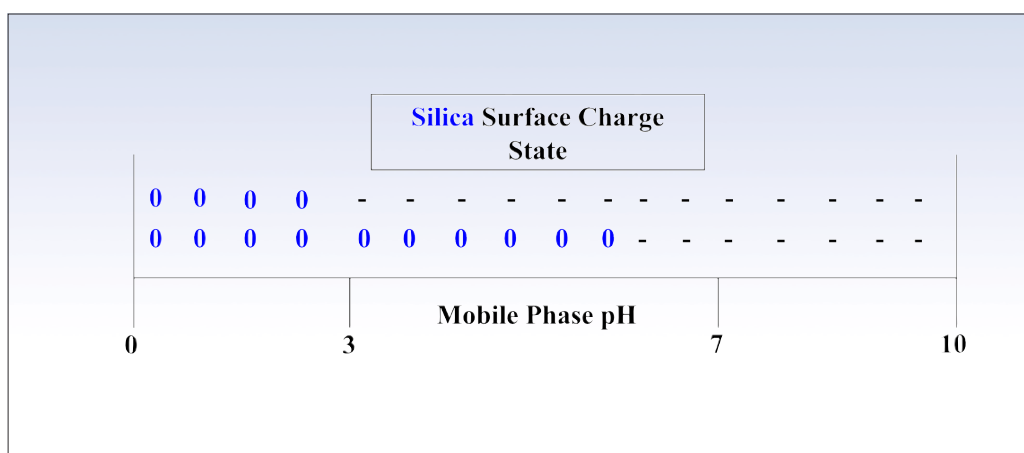

Figure 7. Depiction of the theoretical effect of mobile phase pH on the charge state of the silica surface as silanol groups become protonated or deprotonated.

The large, but variable negative charge of the zirconia surface of ZirChrom[®]-EZ and ZirChrom[®]-MS contribute significantly to the retention of cationic solutes, under conditions where the analyte is charged, through an ion-exchange retention mechanism. Figure 8 shows the logarithm of the retention factor for a series of benzylamines versus the logarithm of the counterion concentration in the mobile phase on ZirChrom[®]-EZ. The linearity of this plot indicates that these positively charged benzylamine analytes do indeed interact with surface through an ion-exchange mechanism. A similar characteristic is seen with the ZirChrom[®]-MS column.

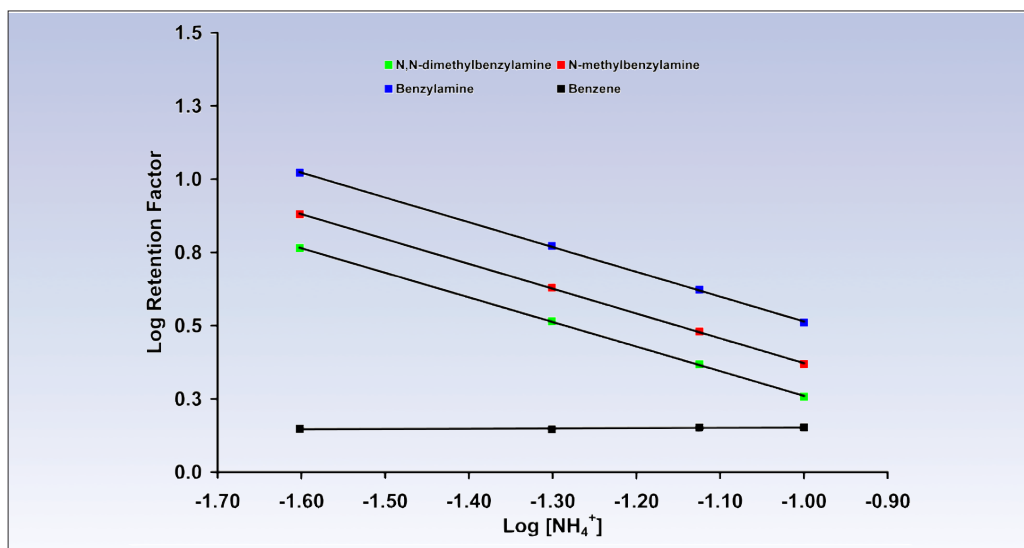

Figure 8. Plot of the logarithm of the retention factor for a series of benzylamines versus the logarithm of the counterion concentration in the mobile phase. LC Conditions: Column, 50 mm x 4.6 mm i.d. ZirChrom[®]-EZ (part# EZ01-0546); Mobile phase, 15/85 ACN/5mM MES w/ 25, 50, 75, or 100mM ammonium acetate, pH 6.0; Flow rate, 2.0 ml/min.; Temperature, 35 °C; Injection volume, 5 µl; Detection at 254 nm.

A practical result of the increased contribution of the ion-exchange mechanism to the retention of cationic solutes on ZirChrom[®]-EZ and -MS is that the chromatographic selectivity for a variety of basic pharmaceuticals is quite different compared to typical ODS phases. Figure 9 shows a selectivity comparison of ZirChrom[®]-MS versus a leading bonded phase C18 silica for basic drugs. The large amount of scatter in this plot indicates that the selectivity for these compounds on ZirChrom[®]-MS is quite different compared to the ODS phases. For example, the removal of a methyl group from the amine group of amitriptyline to give nortriptyline causes a decrease in retention on the ODS phase, while causing an

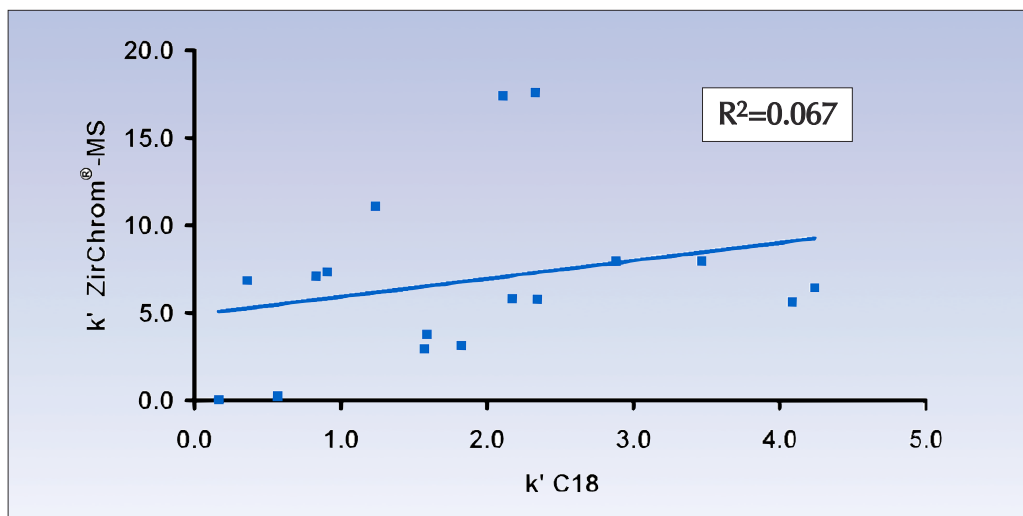

Figure 9. Selectivity comparison of ZirChrom®-MS versus a leading bonded phase C18 silica for basic drugs. **LC Conditions:** Column, 50 mm x 4.6 mm i.d. ZirChrom®-MS (part# MS01-0546); Mobile phase, 80/20 ACN/10 mM ammonium acetate, pH=6.7 without pH adjustment; Flow rate, 1.0 ml/min.; Temperature, 35 °C; Injection volume, 0.1 µl; Detection at 254 nm; Solutes (Basic Drugs): Methapyrilene, Pyrilamine, Tripeleneamine, Chlorpheniramine, Brompheniramine, Thiothixene, Doxepin, Amitriptyline, Desipramine, Nortriptyline, Pyridine, Imipramine, Lidocaine, Atenolol, Metoprolol, Oxprenolol, Alprenolol.

increase in retention on the ZirChrom®-MS phase!

Since the surface chemistry of the ZirChrom®-EZ and ZirChrom®-MS phases are essentially fixed by the deactivation of the Lewis acid sites, the type of mobile phase buffer that is used has little effect. However, the pH of the mobile phase that is used, and the concentration of the mobile phase buffers and additives that are used will have profound effects on the retention of cationic analytes. Three general rules apply to the retention of cationic solutes on ZirChrom®-EZ and ZirChrom®-MS.

1. Below the pKa of the analyte, decreasing the mobile phase pH will cause a decrease in retention.
2. Above the pKa of the analyte, increasing the mobile phase pH will cause a decrease in retention.
3. Below the pKa of the analyte, increasing the concentration of a positively charged counterion (i.e. Na⁺, NH₄⁺) in the mobile phase will cause a decrease in retention.

Additionally, both ZirChrom®-EZ and ZirChrom®-MS generally exhibits higher retention for cationic solutes than do other zirconia-based reversed-phase materials such as ZirChrom®-PBD and ZirChrom®-PS. This is particularly important in LC/MS applications where the retention of cationic solutes on ZirChrom®-EZ and ZirChrom®-MS is more dependent on mobile phase pH than the type of buffer used in the mobile phase. This certainly is not the case with ZirChrom®-PBD where phosphate buffers are necessary to increase retention of cationic solutes at low pH (see ZirChrom's Reversed-Phase Method Development Guide for ZirChrom®-PBD, ZirChrom®-PS, ZirChrom®-CARB, and DiamondBond®-C18). Figure 10 compares the retention observed on ZirChrom®-PBD and ZirChrom®-EZ, for cationic pharmaceuticals, in acetate buffers. ZirChrom®-EZ clearly provides much more retention of these common cationic pharmaceuticals in acetate buffers commonly used for LC/MS.

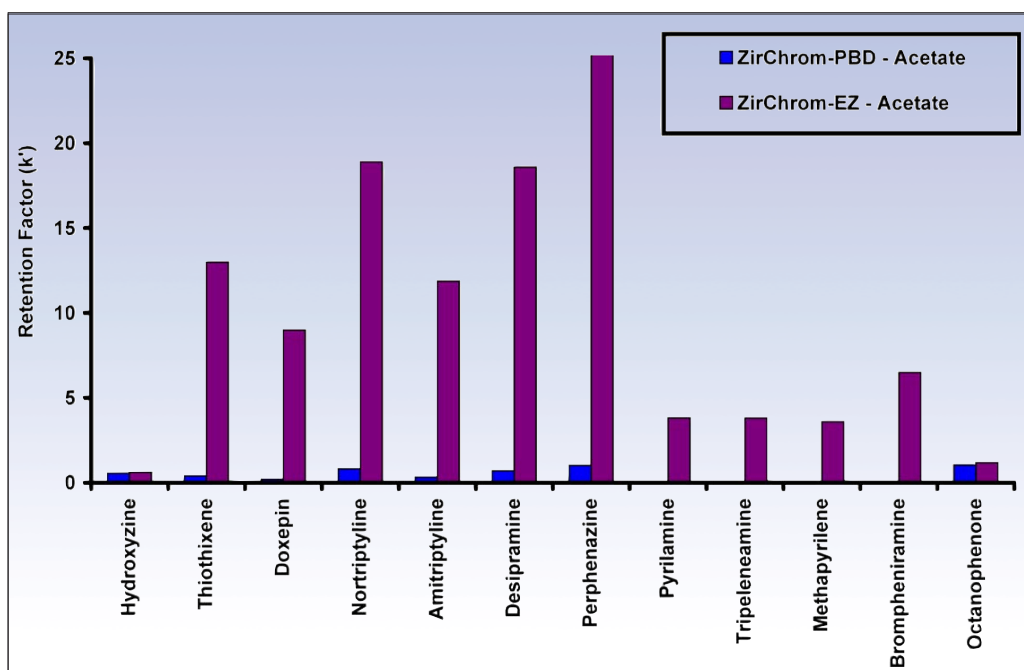

Figure 10. Retention of basic drugs as a function of buffer type on ZirChrom®-PBD and ZirChrom®-EZ. LC Conditions: Columns, 50 mm x 4.6 mm i.d.; Mobile phase, 72/28 MeOH/25mM Ammonium acetate, 5mM (2-[N-morpholino]ethanesulfonic acid), pH 6.0; Flow rate, 1.0 ml/min.; Temperature, 35 °C; Injection volume, 5 µl; Detection at 254 nm.

Figure 11 shows a retention comparison of ZirChrom®-MS versus a leading bonded phase C18 silica for basic compounds under LC-MS compatible

operating conditions. For illustrative purposes the solutes are organized in order of increasing retention on ZirChrom®-MS. This figure demonstrates that ZirChrom®-MS offers enhanced retention for basic pharmaceutical compounds compared to bonded phase C18 silica.

Among this same set of basic drugs ZirChrom®-MS produced markedly superior column efficiency (plates per meter) and symmetry in 16 out of 17 cases (refer to TB#303 for further details). Under these operating conditions the bonded phase C18 silica column only produced acceptable column performance results for acidic and neutral compounds.

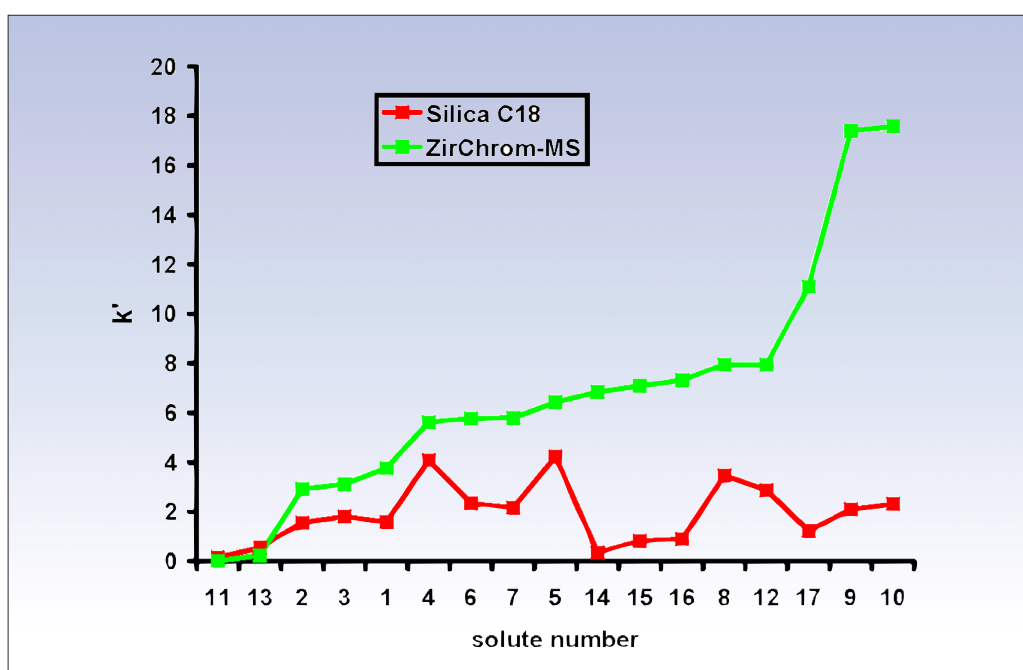

Figure 11. Retention comparison of ZirChrom®-MS versus a leading bonded phase C18 silica for basic drugs (plotted in order of increasing retention on ZirChrom®-MS). LC Conditions: Column, 50 mm x 4.6 mm i.d. ZirChrom®-MS (part# MS01-0546); Mobile phase, 80/20 ACN/10 mM ammonium acetate, pH=6.7 without pH adjustment; Flow rate, 1.0 ml/min.; Temperature, 35 °C; Injection volume, 0.1 ml; Detection at 254 nm; Solutes (Basic Drugs): (1) Methapyrilene, (2) Pyrilamine, (3) Tripeleneamine, (4) Chlorpheniramine, (5) Brompheniramine, (6) Thiothixene, (7) Doxepin, (8) Amitriptyline, (9) Desipramine, (10) Nortriptyline, (11) Pyridine, (12) Imipramine, (13) Lidocaine, (14) Atenolol, (15) Metoprolol, (16) Oxprenolol, (17) Alprenolol.

Method Development for Acidic (Anionic) Analytes

In the preceding sections we discussed some of the similarities and differences between ZirChrom[®]-EZ, ZirChrom[®]-MS and other zirconia- and silica-based reversed phases. The most important feature of ZirChrom[®]-EZ and ZirChrom[®]-MS with respect to method development for acidic analytes is the deactivation of the Lewis acid sites on the zirconia surface. If they are not deactivated, these Lewis acid sites interact rather strongly with free unpaired electron of Lewis base molecules or moieties commonly found in number of analytes. These moieties include carboxylates, phosphates, sulfates, etc. In the worst case, this interaction can lead to irreversible adsorption of analyte molecules at Lewis acid sites.

Fortunately, these problems no longer exist with ZirChrom[®]-EZ and ZirChrom[®]-MS. The deactivation of the Lewis acid sites by their chelation with EDTPA as shown in Figure 5 means that any buffer can be used when developing methods for acidic analytes. In fact, to demonstrate the deactivation of the zirconia surface, Figure 12 shows the chromatography of a

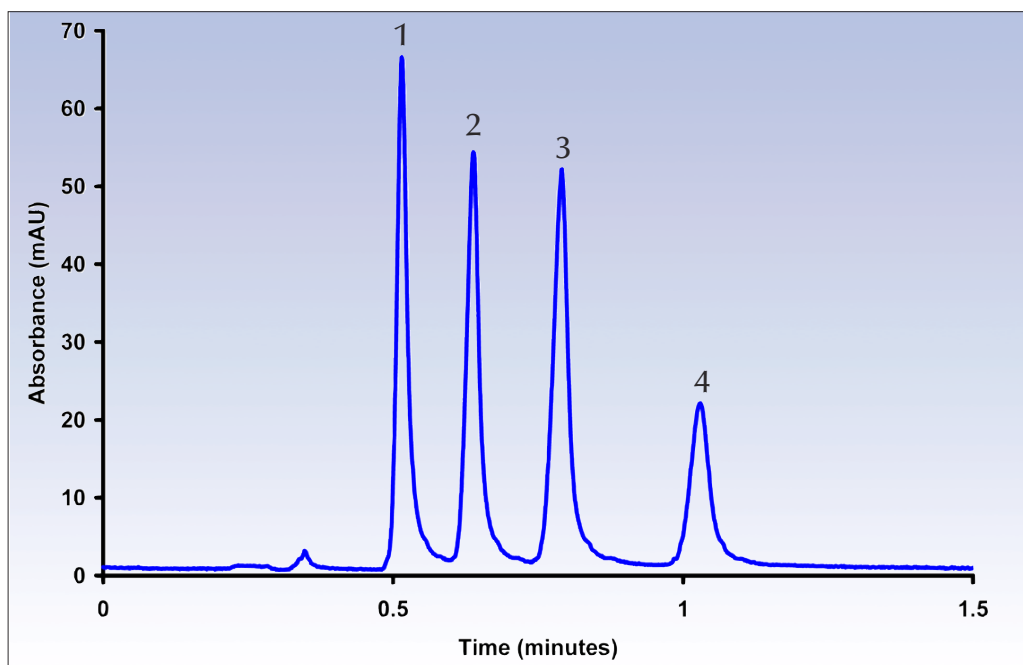

Figure 12. Alkoxybenzoic acid separation in an ACN/water mobile phase without any additives. LC Conditions: Column, 50 mm x 4.6 mm i.d. ZirChrom[®]-EZ (part # EZ01-0546); Mobile phase, 40/60 ACN/Water; Flow rate, 1.0 ml/min.; Temperature, 30 °C; Injection volume, 1 µl; Detection at 254 nm; Solutes: 1=methoxybenzoic acid, 2=ethoxybenzoic acid, 3=propoxybenzoic acid, 4=butoxybenzoic acid.

homolog series of alkoxybenzoic acids in a mobile phase containing only acetonitrile and water. While this experiment is a nice demonstration of the power of ZirChrom®-EZ, we do recommend that you include a mobile phase buffer to provide the most reproducible and robust separations of acidic analytes on both ZirChrom®-EZ and ZirChrom®-MS. We recommend that you choose a mobile phase buffer that will provide adequate buffering capacity at the mobile phase pH you intend to maintain. Figure 13 shows the effective pH range of a number of common buffer systems.

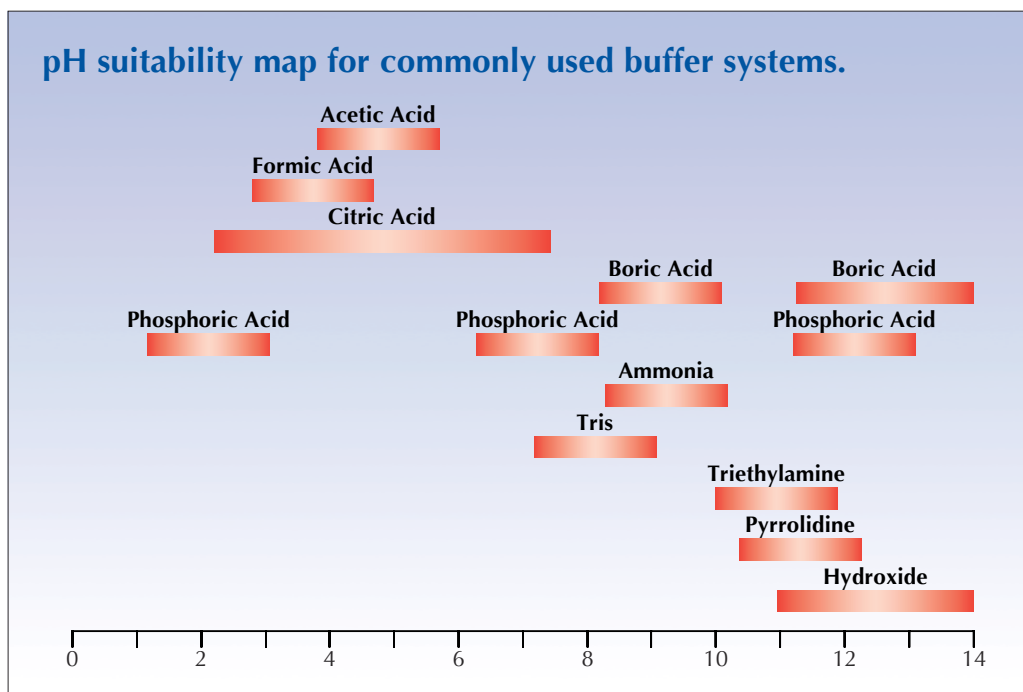

Figure 13. pH suitability map for commonly used buffer systems. The bright region of the buffer range indicates the region of highest buffering capacity.



Using a properly buffered mobile phase, excellent separations of acidic analytes can be obtained. Figure 14 shows the gradient elution of a number of common non-steroidal anti-inflammatory drugs (NSAIDs), all of which contain carboxylic acid moieties, using a simple ammonium acetate buffer at pH 6.

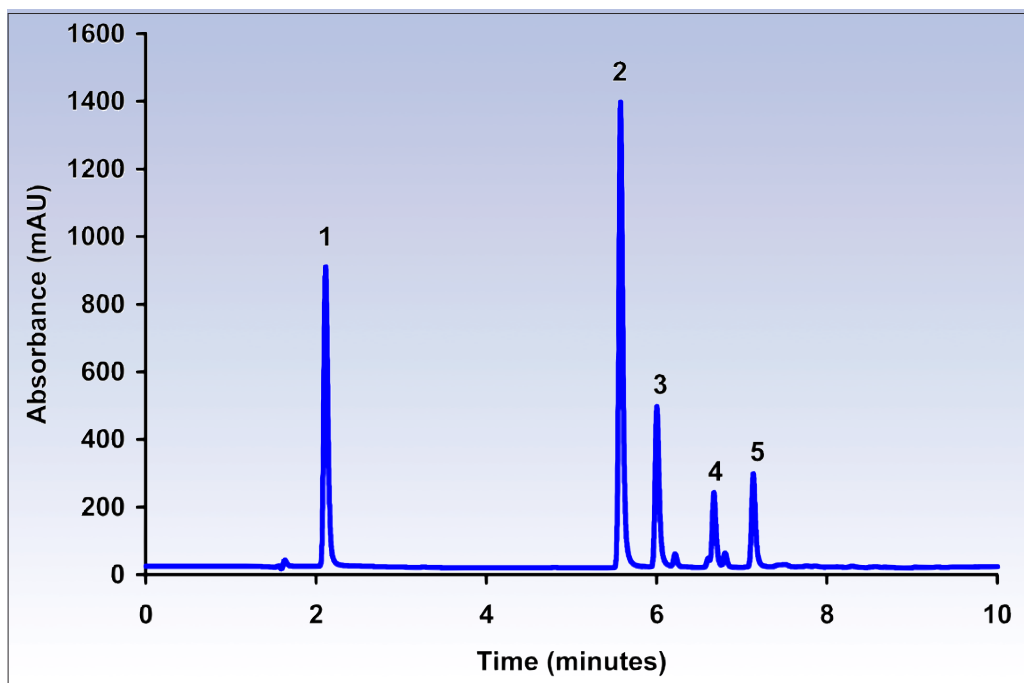

Figure 14. Separation of five non-steroidal anti-inflammatory drugs. LC Conditions: Column, 150 mm x 4.6 mm i.d. ZirChrom[®]-EZ (part # EZ01-1546); Mobile phase, A = 20mM ammonium acetate, pH 5.0, B = ACN, gradient elution from 10-90% B from 0-10 minutes; Flow rate, 1.0 ml/min.; Temperature, 35 °C; Injection volume, 10 µl; Detection at 254 nm.; Solutes: 1=acetaminophen, 2=naproxen, 3=ketoprofen, 4=fenoprofen, 5=indomethacin.



PART III

Other Products & Services

Method Development Kits

Not sure which column is best for your application? Try one of ZirChrom's method development kits. Each kit contains 3 columns with different selectivity for faster screening (columns are 4.6 mm x 50 mm; other sizes are available upon request).

- MK01 Ion Exchange Method Development Kit #1**
(contains 1 each of ZirChrom[®]-SAX,
ZirChrom[®]-SHAX, and ZirChrom[®]-WAX)
- MK02 Ion Exchange Method Development Kit #2**
(contains 1 each of ZirChrom[®]-SAX,
ZirChrom[®]-WCX, and ZirChrom[®]-PEZ)
- MK03 Reversed Phase Method Development Kit #1**
(contains 1 each of ZirChrom[®]-PBD,
ZirChrom[®]-CARB, and DiamondBond[®]-C18)
- MK04 Reversed Phase Method Development Kit #2**
(contains 1 each of ZirChrom[®]-PBD, ZirChrom[®]-CARB,
and ZirChrom[®]-EZ {or ZirChrom[®]-MS})

Particle Sizes

ZirChrom's analytical columns are packed with 3 or 5 micron particles. On request, we can pack columns with 7, 10, or 25 micron particles, or larger, with identical chemistry, making scale-up using ZirChrom's products fast and easy. All particles have 300 angstrom pores.

Non-Porous Zirconia

ZirChrom has available non-porous particles for ultra-fast chromatography. These particles are available in sizes of 0.5, 1.0, 1.5, 2.0 & 3.0 micron and in all of our normal phase and reversed phase chemistries. Ion exchange versions can be custom made. Custom particle sizes up to 3.0 micron in size are available.

Prep Formats

All of our phases are available in semi-prep and prep formats. See our Technical Bulletin #196 for more information on easy scale-up to prep formats.

Microbore and LC/MS Formats

All of our phases are available in microbore and LC/MS formats upon request. Short capillary columns (50 x 0.3 mm i.d., 50 x 0.5 mm i.d. and 50 x 1.0 mm i.d.) packed with the ZirChrom®-MS phase (3 micron particles) are most readily available - refer to technical bulletin #304.

Normal Phase LC /ZirChrom®-PHASE

Unmodified zirconia particles make an excellent support for normal phase LC. ZirChrom®-PHASE is packed into the same column formats as our reversed phase and ion exchange supports. Specify ZR02 when ordering.

Technical Support

ZirChrom's products are often used in cutting edge separations where silica supports fail. Our technical support group has extensive experience, particularly in pharmaceutical and environmental HPLC. We are happy to assist you with your difficult separations.

Buffer Wizard

The ZirChrom® BUFFER WIZARD is a web-based laboratory consultant designed to do the calculations needed to prepare buffers specifically for use in HPLC. In addition to doing the calculations it provides many helpful hints as to the proper choice of buffer and issues messages when the buffer capacity is too low to do the job or when high or low pH might damage fragile silica stationary phases.

To access the Buffer Wizard and other HPLC relevant data, visit the ZirChrom® Home Page (www.zirchrom.com).

An advanced version of the Buffer Wizard with 50 buffer systems is available for sale (part# BW01; \$100.00 list price).

Technical Support

Our technical support group has extensive experience, particularly in pharmaceutical and environmental HPLC. We are happy to assist you with your difficult separations. Please contact us at 1-866-STABLE-1 or support@zirchrom.com.

For Peak Performance

ZirChrom® manufactures a full line of zirconia-based high performance products used for the analysis of compounds by HPLC.



ZirChrom Separations, Inc.

617 Pierce Street
Anoka, MN 55303

T: 1-866-STABLE-1 (1-866-782-2531)

F: 1-763-421-2319

www.zirchrom.com

support: support@zirchrom.com

ZirChrom®, ZirChrom®-EZ, ZirChrom®-MS, ZirChrom®-PBD, ZirChrom®-PS, ZirChrom®-CARB, and DiamondBond®-C18 are registered trademarks of ZirChrom Separations, Inc.

© 2004 ZirChrom Separations, Inc.
Printed in the U.S.A., May 2004



tel 1-866-STABLE-1 / fax 1-763-421-2319 / www.zirchrom.com