

# Microfluidic Connections

Connectors, Fittings, Filters, Tubing, Valves, and Accessories

Designed for Microscale and Nanoscale Applications  
including connections for very high-pressure applications

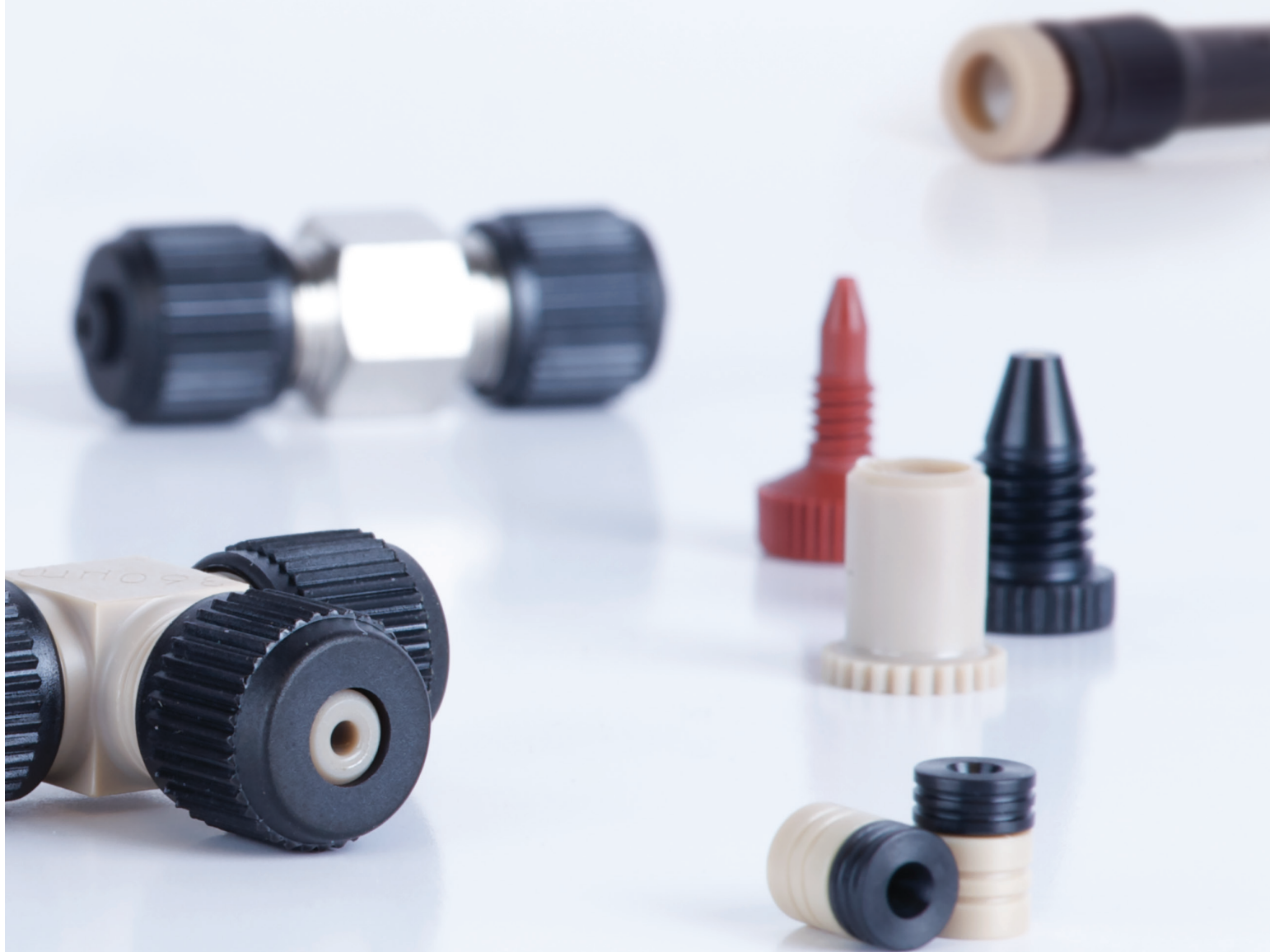

## Need Help With Microscopic Fluid Transfer?

This brochure features IDEX Health & Science's Upchurch Scientific® products that are designed to simplify your micro- and nanoscale applications, including Lab-on-a-Chip, Microbore HPLC and CEC — as well as components for interfacing hyphenated systems such as LC-MS and GC-MS. You will also find fittings and sleeves to facilitate fused silica and other capillary tubing connections, along with a variety of accessories designed for microscopic flow rates.

### Table of Contents

|                                                                        |    |
|------------------------------------------------------------------------|----|
| NanoPort™ Assemblies for Lab-on-a-Chip applications .....              | 2  |
| Capillary Sample Trap Columns .....                                    | 3  |
| Micro Static Mixing Tees for 20–250 µL per minute flow rates .....     | 4  |
| NanoTight™ Y Connector .....                                           | 4  |
| NanoTight Fittings and Capillary Tubing Sleeves .....                  | 5  |
| Conductive Perfluoroelastomer Ferrule for Mass Spec Electrospray ..... | 5  |
| MicroTight® Fittings .....                                             | 6  |
| Unions .....                                                           | 7  |
| Adapters .....                                                         | 8  |
| MicroTees/Crosses/Elbows .....                                         | 8  |
| MicroFilters .....                                                     | 9  |
| Capillary and Microbore Tubing.....                                    | 11 |
| OEM Custom Components and Capabilities.....                            | 13 |
| Technical Resources .....                                              | 14 |

Visit our website for detailed information on trademarks and registered trademarks, as well as IDEX Health & Science news, events, and new product information.

### IDEX Health & Science LLC

Tel (toll free): 800 426 0191

Outside USA: +1 360 679 2528

Fax (toll free): 800 359 3460

Fax Outside USA: +1 360 679 3830

E-mail: [CustomerService.hs@idexcorp.com](mailto:CustomerService.hs@idexcorp.com)

[www.idex-hs.com](http://www.idex-hs.com)



# NanoPort™ Assemblies

- › For Lab-on-a-Chip Applications
- › Wetted materials: PEEK™ and Perlast perfluoroelastomer
- › Options for connecting MicroTight® tubing sleeves, 360 µm OD, 1/32" OD and 1/16" OD tubing

NanoPort Assemblies are the first commercially available products to provide reliable fluid connections for chip-based analyses. These products bond easily to chip surfaces with the provided Preformed Adhesive Rings. Once attached, NanoPort connections withstand pressures to 1,000 psi (69 bar), except the N-333 NanoPort Assembly, which is rated to 500 psi (34.5 bar). NanoPorts will adhere to silicon, quartz, glass and polymers. Their unique design also prevents adhesive contamination of the fluid path. And, because tubing sits directly on the chip surface, NanoPort connections add no additional volume to the fluid path, eliminating dead volume traditionally associated with chip-based connections.

The NanoPort Reservoir Assembly (80 µL volume) is designed for open-well applications, such as CE.

## Literature References on NanoPort Applications

- › Hulvey, Matthew and Martin, R. Scott. "A Microchip-based Endothelium Mimic Utilizing Open Reservoirs for Cell Immobilization and Integrated Carbon Ink Microelectrodes for Detection." *Analytical & Bioanalytical Chemistry*. January 2009: 393(2): 599–605
- › Li, Chen and Lee, Kelvin. "Affinity depletion of albumin from human cerebrospinal fluid using Cibacron-blue-3G-A-derivatized photopatterned copolymer in a microfluidic device." *Analytical Biochemistry*: 2004: 333: 281–288
- › Haapala, Markus, Luosujärvi, Laura, Saarela, Ville, Kotiaho, Tapio, Ketola, Raimo A., Franssila, Sami and Kostianen, Risto. "Microchip for Combining Gas Chromatography or Capillary Liquid Chromatography with Atmospheric Pressure Photoionization-Mass Spectrometry." *Analytical Chemistry*. May, 2007: 79: 4994–4999

### APPLICATION NOTE

#### NanoPort Adhesive Cure Requirements

- › Preformed Adhesive Rings

| Cure Temperature | Cure Time |
|------------------|-----------|
| 325° F/163° C    | 1 hour    |

- › Please contact us regarding adherence to specific polymer substrates and other adhesive options.

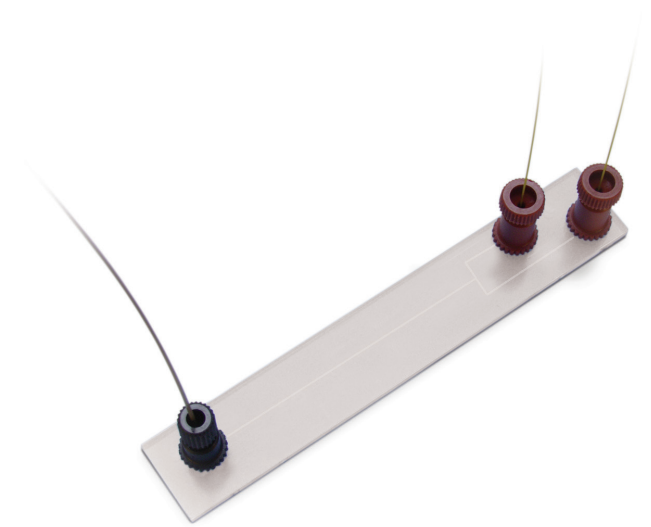

Please Note: All measurements below are in mm.

#### 6-32 Flat-Bottom Assemblies

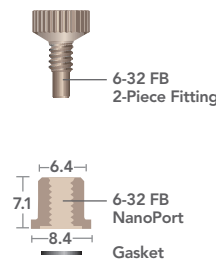

#### 6-32 Coned Assemblies

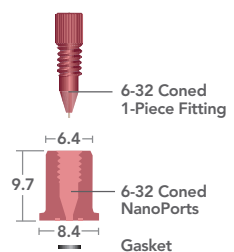

#### 10-32 Flat-Bottom Assemblies

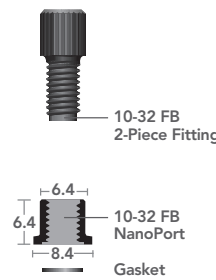

#### 10-32 Coned Assembly

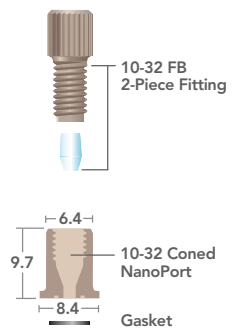

#### Reservoir Assembly

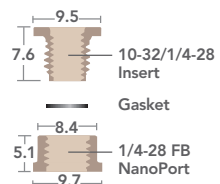

## Capillary Sample Trap Columns

- › Optimized for protein and peptide separation/purification
- › Designed to directly connect to 360 µm OD tubing
- › Packed and unpacked columns

Capillary Sample Trap Columns are ideal for separating and concentrating and/or purifying biological samples. These products can be used for rapid sample analysis, or they can be placed inline with an injection loop for sample preparation. Capillary Sample Trap Columns can also function as nanobore guard columns.

The heart of the Sample Trap is a fused silica capillary column. Available packing includes: reversed-phase C18, high-carbon load, 5 µm / 300Å spherical silica; and a SCX (Strong Cation Exchange) 5 µm / 85Å material. Each column supports a recommended maximum sample loading capacity of approximately 0.1 µg with a capillary bed volume at 0.19 µL or less. Unpacked and Conductive Column Assemblies are also available.

Capillary Sample Trap Column Assemblies include one or more 1 µm NanoFilter™ Capsules, each containing either a stainless steel (SST) or biocompatible titanium (Ti) frit (see page 9). Connect your 360 µm OD capillary tubing directly to our Sample Trap Column Assemblies using the fittings provided. Each Capillary Sample Trap Column Assembly is rated to 5,000 psi (345 bar).

Also try our Column Coupler, which makes it possible to connect two or more columns in sequence.

### Sample Trap Column Assembly Components Chart:

Please refer to the drawing and part numbers below when ordering replacement components:

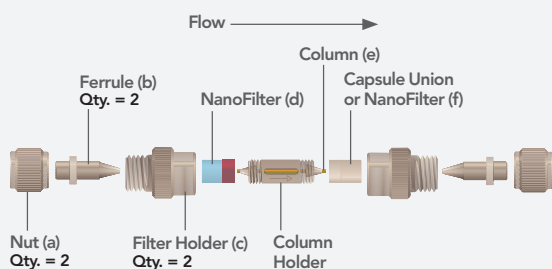

| Column Assembly       | Nuts (a) | Ferrules (b) | Filter Holder Color (c) | NanoFilter (d) | Column (e)            | Capsule Union or NanoFilter (f) |
|-----------------------|----------|--------------|-------------------------|----------------|-----------------------|---------------------------------|
| <b>Non-Conductive</b> |          |              |                         |                |                       |                                 |
| C-1200                | P-416    | F-152        | Tan                     | M-125 (SST)    | C-1250 (C18)          | M-124NF (no frit)               |
| C-1300                | P-416BLK | F-152        | Tan                     | M-126 (Ti)     | C-1250 (C18)          | M-124NF (no frit)               |
| C-1400                | P-416G   | F-152        | Black                   | M-126 (Ti)     | C-1450 (SCX)          | M-124NF (no frit)               |
| C-1500                | P-416    | F-152        | Tan                     | M-125 (SST)    | FS-1000-25 (unpacked) | M-125 (SST)                     |
| C-1600                | P-416BLK | F-152        | Tan                     | M-126 (Ti)     | FS-1000-25 (unpacked) | M-126 (Ti)                      |

All nuts, ferrules, and column holders are made of PEEK polymer. Filter holders are made of PEEK polymer. NanoFilter Capsule bodies are made of PEEK polymer.

Abbreviation Key: SST = Stainless Steel; Ti = Titanium; SCX = Strong Cation Exchange

### Example Separation Chromatogram of Five Angiotensins

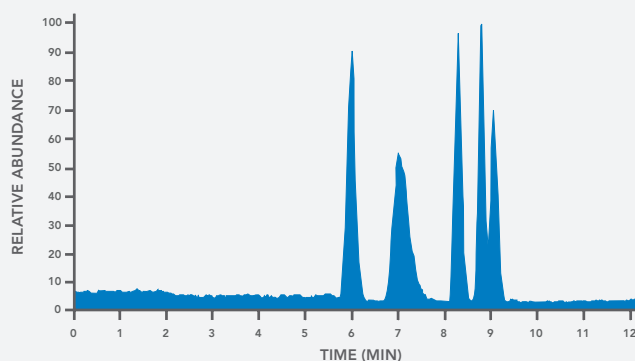

#### Chromatographic Conditions, using C18 Sample Trap Column:

**Binary Gradient** A: Water; B: Acetonitrile w/0.1% Formic Acid

- Gradient Profile**
- › 2% B for 0.1 minutes
  - › Ramp to 95% B over 10 minutes
  - › Hold at 95% B for 4 minutes
  - › Return to 2% B over 1 minute

**Flow Rate** 250 nL/minute

## Micro Static Mixing Tee

The Micro Static Mixing Tee combines two flow streams. It features a center port, which incorporates a 0.5 µm PEEK™ polymer frit to aid mixing. This frit adds no more than 20 psi (1.4 bar) additional back pressure to most systems (within the stated flow rate range).

Micro Static Mixing Tees support 20–250 µL/min flow rates with a void volume of only 0.95 µL, including frit volume. Constructed of PEEK and Kel-F® (PCTFE), this mixing tee is chemically resistant and 100% biocompatible. It handles a maximum pressure of 5,000 psi (345 bar). When connecting to the tee with capillary tubing, use our NanoTight™ Sleeves shown on page 5. No sleeves are required for 1/16" OD tubing.

*Please Note: Turbulent mixing of solvents often increases outgassing; therefore, we recommend solvent degassing when using this product.*



**M-540**  
Micro Static Mixing Tee

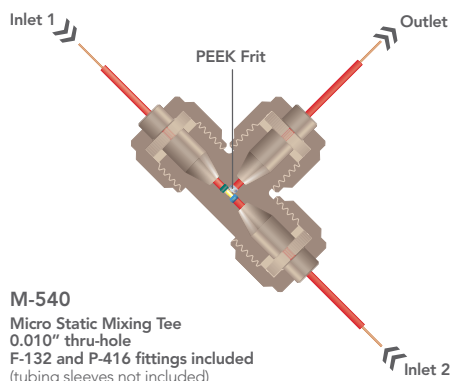

**M-540**  
Micro Static Mixing Tee  
0.010" thru-hole  
F-132 and P-416 fittings included  
(tubing sleeves not included)

## NanoTight Y Connector

› Only 17 nL void volume!

This product improves laminar flow over traditional MicroTee designs — meaning less turbulence and mixing when combining two fluid paths or splitting one fluid path into two.

The NanoTight Y Connector's PEEK polymer body incorporates a 1.6" long Teflon® FEP Dual-Lumen NanoTight Tubing Sleeve to accommodate two 360 µm OD capillary tubing lines. The opposite end uses our F-242 NanoTight Tubing Sleeve (also FEP for 360 µm OD) for the single inlet or outlet flow path.

This assembly will hold up to 4,000 psi (276 bar). Furthermore, with its 0.004" (102 µm) thru-hole and miniscule 17 nL void volume, the Nano Y does not contribute significantly to band broadening or mixing effects.

The NanoTight Y Connector includes sleeves and NanoTight Fittings, as shown on page 5. For replacement NanoTight Tubing Sleeves and fittings see the Product Listing Sheet. Besides the included single lumen sleeves (for 360 µm OD), you can choose from other available sleeves to connect capillary tubing with ODs ranging from 70 µm to 1 mm.

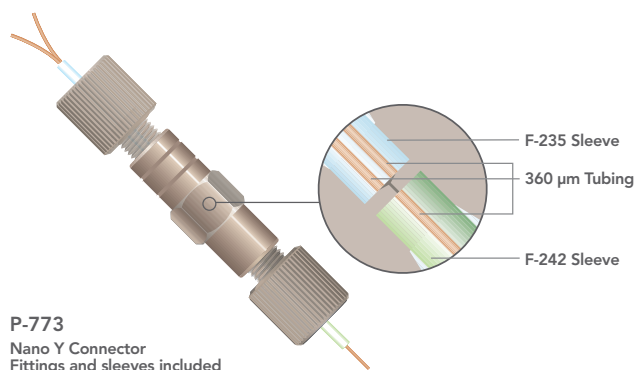

**P-773**  
Nano Y Connector  
Fittings and sleeves included

## NanoTight™ Fittings

- › For connecting capillary tubing into 10-32 coned ports

NanoTight fittings offer the best available option for connecting capillary tubing into standard 10-32 threaded, coned ports normally designed for 1/16" OD tubing. These specialized versions of our popular Two-Piece Fingertight fittings combine sturdy, chemically inert PEEK™ polymer nuts with a high-pressure ferrule manufactured from (ETFE) polymer. When combined with NanoTight Tubing Sleeves discussed below, these fittings work with a wide range of capillary tubing ODs (see Product Listing Sheet) and will hold up to 4,000 psi (276 bar) — even with repeated use. Please contact us for additional nut styles.

## Ferrules for Direct Connecting Capillary Tubing

- › PCTFE and conductive perfluoroelastomer versions
- › No sleeves needed

Use the F-151 PCTFE ferrule with any of our 10-32 threaded nuts to directly connect 360 µm OD capillary tubing to 10-32 coned ports. Suitable nuts are listed on [www.idex-hs.com](http://www.idex-hs.com) or in the Fittings chapter of our IDEX Health & Science Catalog. To order the desired nuts without its standard ferrule, replace the "x" at the end of the product with "-01."

In your electrospray applications, try our M-215 Conductive Perfluoroelastomer Ferrule. Unlike most graphite ferrules, its elastomeric properties permit repeated use to connect 360 µm OD tubing. It also eliminates possible graphite contamination. Yet, like graphite ferrules, you can apply voltage through a metallic port block, allowing voltage into the flow path through the ferrule. When using with a stainless steel nut in a plastic port, simply apply the voltage to the nut. Select and order suitable nuts as described above.

## Sleeves

- › For Connecting Capillary Tubing to Standard Ports

Sleeves let you connect fused silica or other capillary tubing to various standard ports intended for 1/16" and 1/32" OD tubing. Select sleeves with a slightly larger ID than the OD of your capillary tubing. For instance, when connecting 360 µm OD tubing into a 10-32 port, insert the tubing into an F-242 (395 µm ID) NanoTight sleeve.

| Sleeve OD | Type/ Material     | Fitting/Port                                                                   | Capillary Tubing ODs | Max Temp. |
|-----------|--------------------|--------------------------------------------------------------------------------|----------------------|-----------|
| 1/16"     | NanoTight (FEP)    | NanoTight/10-32 Super Flangeless/6-32, 6-40 MINSTAC Compatible TinyTight™/6-40 | 70 µm–1 mm           | 50°C      |
| 1/16"     | PEEK               | 10-32 Stainless Steel (wrench-tightened)                                       | 175–770 µm           | 125°C     |
| .025"     | MicroTight® (PEEK) | MicroTight/6-32                                                                | 70–520 µm            | 125°C     |
| 1/32"     | FEP                | MicroTight/6-32 Valco Nanovolume Compatible/6-40                               | 20–380 µm            | 50°C      |
| 1/32"     | PEEK               | MicroTight/6-32, 6-40 (best suited for higher-pressure applications)           | 70–495 µm            | 125°C     |

NanoTight and MicroTight sleeves also come in convenient kits, which include popular fittings and connectors. Visit [www.idex-hs.com](http://www.idex-hs.com) for all available part numbers/IDs.

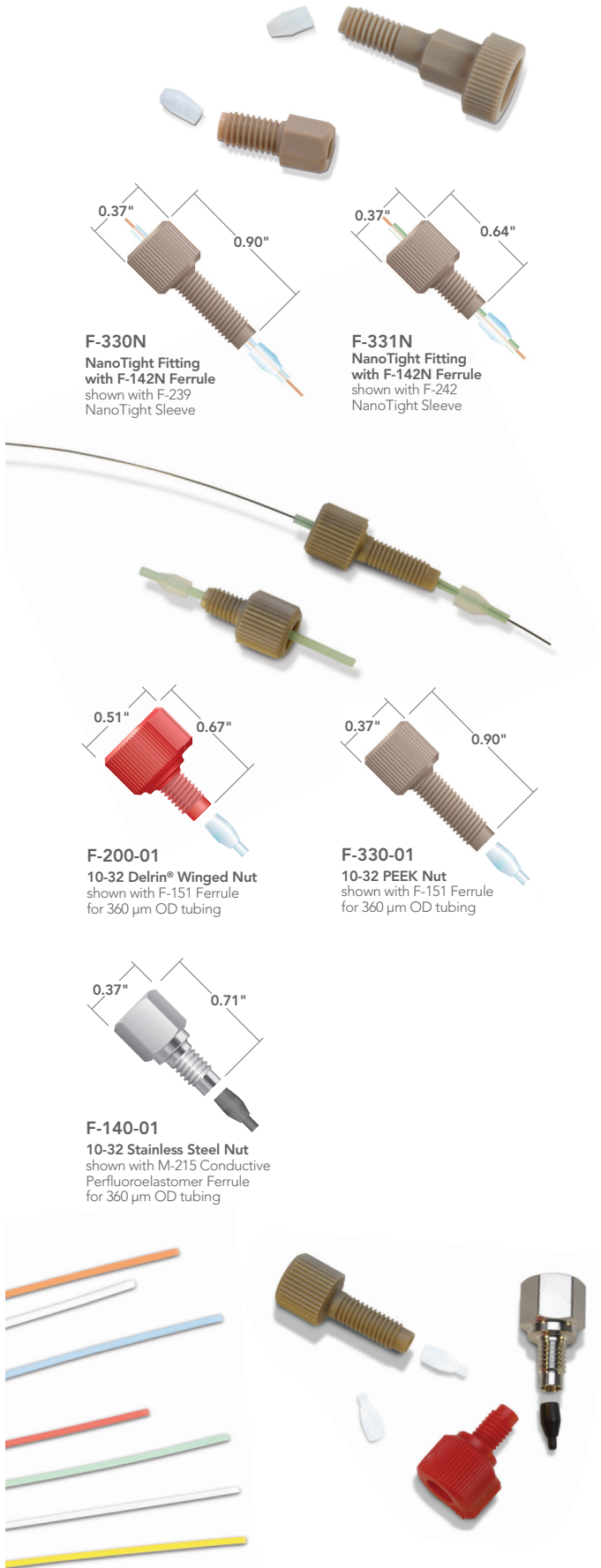

# MicroTight® Fittings

MicroTight one-piece fittings work with MicroTight Unions, Adapters and Inline MicroFilters, as well as NanoPorts™ featured on page 2. As with all of our PEEK™ polymer fittings, MicroTights withstand temperatures up to 125°C. The MicroTight fittings that are used with the MicroTight tubing sleeves (F-125, F-125H, F-172) will hold tubing to 4,000 psi (276 bar). The MicroTight fittings that do not require sleeves are rated to 5,000 psi (345 bar). The very high pressure MicroTight fitting, PK-126 will hold 1/32" OD stainless steel tubing to 15,000 psi (1,034 bar) in a stainless steel port. The PK-152 and PK-112 are also designed to hold to 15,000 psi (1,024 bar).

To tighten one-piece MicroTights and NanoPort nuts in hard-to-reach places, try our P-277 Micro Extender Tool for the standard-head nuts and the N-290 NanoPort Headless Extender Tool for headless versions.

The MicroTight Fittings family also includes a female nut matched with one of five dedicated ferrules for direct connecting specific tubing ODs.

You may seal off unused ports by installing a P-116 MicroFerrule Plug instead of the ferrules (such as in the MicroTees and MicroCrosses shown on page 8).

*Please Note: These ferrules are not interchangeable; they must be used with the products for which they were designed.*

## 6-32 and 6-40 Threaded Fittings

There are several options for connecting 1/16", 1/32" and capillary OD tubing into 6-32 and 6-40 threaded ports — including alternatives for The Lee Company MINSTAC™\*. These are Super Flangeless™ fittings, which consist of a PEEK nut, plus a PEEK ferrule and stainless steel lock ring. The ring allows the fitting to hold to higher pressures than standard flangeless fittings while preventing the tubing from twisting during tightening. The TinyTight™ ferrule system is rated to 600 psi on FEP tubing.

### PRESSURE RATINGS<sup>1, 2</sup>

|                                                                             | Tubing                                                         | Pressure Rating     |
|-----------------------------------------------------------------------------|----------------------------------------------------------------|---------------------|
| <b>Fittings for 6-32 Port</b><br>M-650, M-660                               | FEP, 1/16" OD x 0.010" ID                                      | 1,750 psi (121 bar) |
|                                                                             | PEEK, 1/16" OD x 0.010" ID                                     | 3,750 psi (259 bar) |
|                                                                             | Stainless Steel, 1/16" OD x 0.010" ID                          | 3,750 psi (259 bar) |
|                                                                             | Fused Silica, 360 µm OD x 75 µm ID (using F-242 tubing sleeve) | 750 psi (52 bar)    |
| <b>Fittings for 6-40 Port</b><br>M-650, M-644-03                            | FEP, 1/16" OD x 0.010" ID                                      | 1,750 psi (121 bar) |
|                                                                             | PEEK, 1/16" OD x 0.010" ID                                     | 3,750 psi (259 bar) |
|                                                                             | Stainless Steel, 1/16" OD x 0.010" ID                          | 3,750 psi (259 bar) |
|                                                                             | Fused Silica, 360 µm OD x 75 µm ID (using F-242 tubing sleeve) | 750 psi (52 bar)    |
| <b>Fittings for MINSTAC-Compatible 6-40 Port</b><br>M-647 / M-657, M-644-03 | FEP, 1/16" OD x 0.010" ID                                      | 600 psi (41 bar)    |
|                                                                             | PEEK, 1/16" OD x 0.010" ID                                     | 1,500 psi (103 bar) |
|                                                                             | Stainless Steel, 1/16" OD x 0.010" ID                          | 2,500 psi (172 bar) |

<sup>1</sup> This chart is intended for reference only and refers to the pressure rating of the fittings, NOT the tubing. Tests were conducted with room temperature water as the solvent. Your results may vary depending on the specific port and tubing materials, tubing ID, actual tubing diameters (with manufacturers' tolerances), temperature, chemical compatibility, etc.

<sup>2</sup> The fittings were finger tightened for these tests.

\*IDEX Health & Science's Upchurch Scientific product line includes many products designed as direct replacements for other manufacturers' components. Reference to these companies does not imply their endorsement of our products.

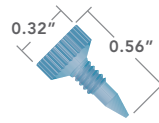

**F-124S**  
Standard Head Fitting  
for use with 360 µm OD tubing

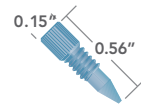

**F-124H**  
Headless Fitting  
for use with 360 µm OD tubing

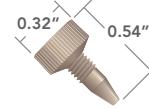

**F-125**  
Standard Head Fitting  
for use with MicroTight Sleeves

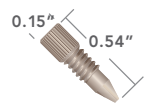

**F-125H**  
Headless Fitting  
for use with MicroTight Sleeves

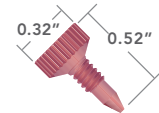

**F-126S**  
Standard Head Fitting  
for use with 1/32" OD tubing

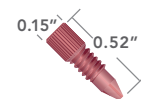

**F-126H**  
Headless Fitting  
for use with 1/32" OD tubing

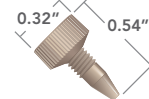

**P-555**  
Standard Head Plug

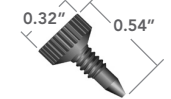

**PK-126x**  
VHP Fitting  
for use with 1/32" OD tubing



**P-416**  
Female Nut  
5/16-24 internal threads



**F-152**  
MicroFerrule  
for 360 µm OD tubing



**F-172**  
MicroFerrule  
for .025" OD tubing



**F-112**  
MicroFerrule  
for 1/32" OD tubing



**P-116**  
MicroFerrule Plug



**F-132**  
MicroFerrule  
for 1/16" OD tubing



**PK-112**  
VHP MicroFerrule  
for 1/32" OD tubing



**PK-152**  
VHP MicroFerrule  
for 360 µm OD tubing



**M-647**  
TinyTight Ferrule  
for 1/16" OD tubing  
0.020" thru-hole



**M-657**  
TinyTight Ferrule  
for 1/16" OD tubing  
0.030" thru-hole



**M-650**  
Super Flangeless Ferrule  
for 1/16" OD tubing

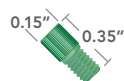

**M-644-03**  
Headless Nut  
6-40 threads

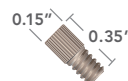

**M-660**  
Headless Nut  
6-32 threads



## NanoTight™ Unions

These unions improve capillary tubing connections in several ways. The sleeving system and internal design of the unions greatly reduce the incidence of misalignment, and the thin internal web's 0.005" (127 µm) or 0.007" (180 µm) thru-hole (P-779-01) protects fragile fused silica at the junction point while adding only miniscule void volume (8 nL for the P-779-01 PEEK™ version and 13 nL for the stainless steel U-411).

**Results: fewer blockages, fewer flow rate reductions and fewer back pressure problems.**

Connect capillary tubing to the unions using NanoTight Fittings and NanoTight Sleeves described on page 5. These versatile unions also work to connect capillary tubing to 1/16" OD tubing, or to connect two 1/16" OD tubing lines. To connect 1/16" OD tubing with our P-779-01, use any standard polymer 10-32 coned fittings, such as our NanoTight Fittings. When connecting 1/16" OD tubing with our U-411 union, use the included fittings.

**Please Note:** For capillary tubing connections with the U-411, use wrench-tightened PEEK Tubing Sleeves, or replace the stainless steel fittings with polymer equivalents before using NanoTight Sleeves.

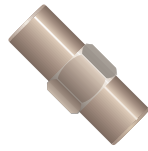
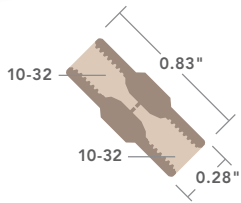

**P-779-01**  
NanoTight Union  
0.005" thru-hole

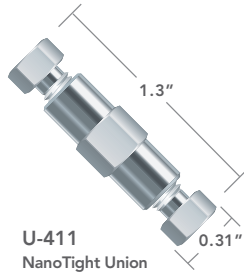

**U-411**  
NanoTight Union  
0.007" thru-hole  
Fittings included

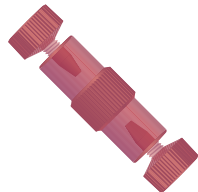
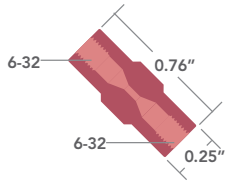

**P-771**  
MicroTight True  
ZDV Union  
for 1/32" OD tubing  
Fittings and gauge plug  
included

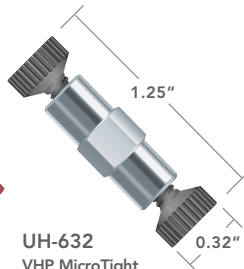

**UH-632**  
VHP MicroTight  
Union for 1/32"  
OD tubing  
Fittings included

## MicroTight® Unions

Use these unions to connect two pieces of fused silica or other capillary tubing. Choose from our selection of MicroTight Tubing Sleeves (page 5 and Product Listing Sheet) to use with the true zero dead volume (ZDV) P-720 Union. The P-771 ZDV Union allows direct connection of 1/32" OD tubing without sleeves. The P-772 Union allows direct connection of popular 360 µm OD capillary/fused silica tubing without sleeves, adding only 5 nL of swept volume with its 0.006" (150 µm) thru-hole.

For very high-pressure connections, use the UH-632 to connect 1/32" OD tubing in a true ZDV union rated to 15,000 psi (1,034 bar) and UH-436 to connect 360 µm tubing in an ultra low volume union with 5 nL of swept volume.

### A Word About Volume...

We use the term "void volume" in this brochure to mean total internal volume. Void volume equals the sum of swept volume (in the intended flow path) and dead volume (outside the intended flow path). Ideally, void volume will equal swept volume, leaving zero dead volume. Keeping dead volume as low as possible is especially important in capillary connections to prevent undesirable effects, such as analysis delays, broadened and/or split peaks, poor resolution, sample carryover and gas collection.

True zero dead volume (ZDV) connections are created when the ends of the two pieces of tubing touch directly in the middle of the connector, so there is no additional volume introduced by the connector to the flow path. Care must be taken when creating these connections using the proper gauge plugs to make sure the tubing is positioned in the middle of the connector.

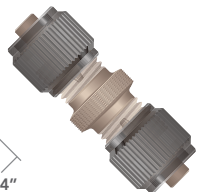
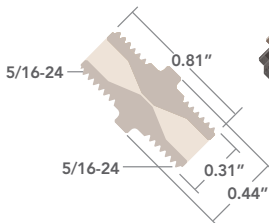

**P-772**  
MicroTight Union  
0.006" thru-hole  
for 360 µm OD tubing  
Fittings included

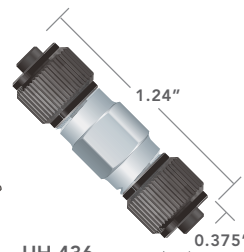

**UH-436**  
VHP MicroTight Union  
for 360 µm OD tubing  
Fittings and capsule  
union included

## MicroTight® Adapters

Create a true zero dead volume (ZDV) connection between 1/16" OD tubing and capillary tubing with these PEEK™ adapters. P-770 connects 1/16" OD tubing to a variety of capillary tubing sizes using 0.025" OD MicroTight Tubing Sleeves (page 5) and is pressure rated to 4,000 psi (276 bar). Our P-881 and P-882 Adapters allow connection of 1/16" OD tubing directly to 1/32" OD and 360 µm tubing respectively, and are pressure rated to 5,000 psi (345 bar). For very high pressure applications, use the UH-630 adapter to connect 1/16" to 1/32" OD tubing when pressures go to 15,000 psi (1,034 bar).

**Please Note:** Use only the 6-32 threaded fitting supplied with each adapter — they are not interchangeable. Replacement 6-32 fittings are on page 6 and the Product Listing Sheet. Replacement F-120R and F-120B nuts are listed in the current IDEX Health & Science catalog and on [www.idex-hs.com](http://www.idex-hs.com).

## MicroTees, MicroCrosses and MicroElbow

Use MicroTees, MicroCrosses or MicroElbow to join capillary tubing. All have 0.006" (150 µm) thru-holes, with resulting void volumes as follows:

|                      | PEEK  | SST    |
|----------------------|-------|--------|
| <b>MicroTees:</b>    | 29 nL | 84 nL  |
| <b>MicroCrosses:</b> | 38 nL | 101 nL |
| <b>MicroElbow:</b>   | 20 nL | N/A    |

The standard products are made entirely of PEEK polymer and will accept only the supplied ferrules (or the P-116 MicroFerrule Plug). Versions are available to make capillary tubing connections using MicroTight Tubing Sleeves (page 5) or direct connections for 360 µm and 1/32" OD tubing. The MicroElbow and one version of the MicroTee (P-875) come with convenient predrilled 0.13" (3.3 mm) mounting holes.

For very high pressure applications, stainless steel versions of these fittings with the VHP MicroTight ferrules will provide reliable connections up to 15,000 psi (1,034 bar).

### APPLICATION NOTE

Several researchers have used our PEEK MicroTee to introduce ionizing voltage to their fluid stream just prior to a Mass Spectrometer<sup>1</sup>. The P-775 and P-875 MicroTees are well suited for this application due to their internal geometry and PEEK polymer's electrical resistance. This setup requires one gold or platinum conducting wire, one P-775 or P-875 MicroTee (this page), one MicroTight Tubing Sleeve (page 5) for the conducting wire (as needed to accommodate wire diameter), and at least two more MicroTight Tubing Sleeves to connect your capillary tubing.

Connect the wire to the center port of the MicroTee. First, thread your wire through the appropriate tubing sleeve, if necessary, with the wire extending well beyond both ends of the sleeve. Then slip the female nut included with the MicroTee over the wire or sleeved wire, followed by the ferrule, ensuring the wire (and its sleeve) extends well past the end of the ferrule tip. Align the tip of the wire with thru-hole of the MicroTee and gently insert the wire until it bottoms out. Now finger tighten the female nut into place. Attach your flow path tubing to the MicroTee's two other available ports, following the instructions provided with the MicroTee.

Begin fluid flow through the tee and apply voltage to the conducting wire lead. This setup typically provides effective electrospray ionization in applications having a flow rate of 100 µL/min or greater.

<sup>1</sup> One paper that describes pioneering electrospray work. Su, Shuqin, Gibson, Graham T. T., Mugo, Samuel M., Marecak, Dale M. and Oleschuk, Richard D. "Microstructured Photonic Fibers as Multichannel Electrospray Emitters." *Analytical Chemistry*. 2009: 81: 7281-7287.

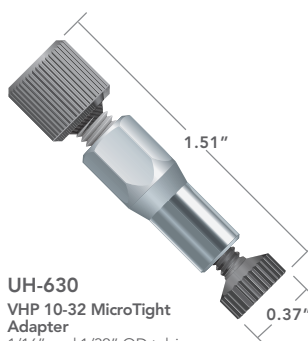
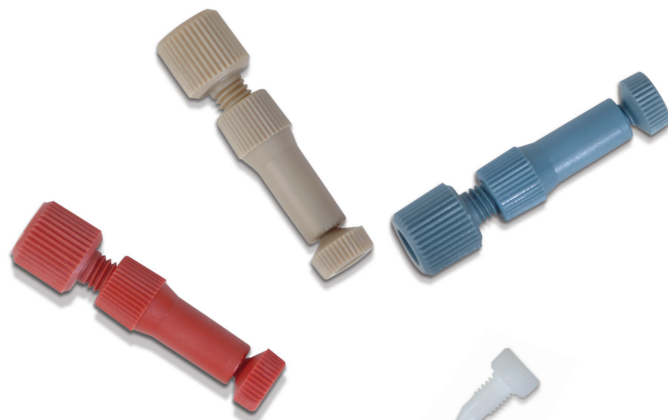

**UH-630**  
VHP 10-32 MicroTight Adapter  
1/16" and 1/32" OD tubing with fittings included

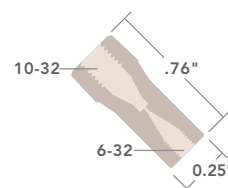

**P-770**  
MicroTight ZDV Adapter  
F-125 and F-120 fittings included

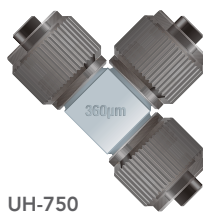

**UH-750**  
VHP MicroTee  
for 360 µm OD tubing with fittings included

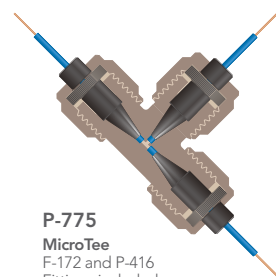

**P-775**  
MicroTee  
F-172 and P-416 Fittings included (tubing sleeves not included)



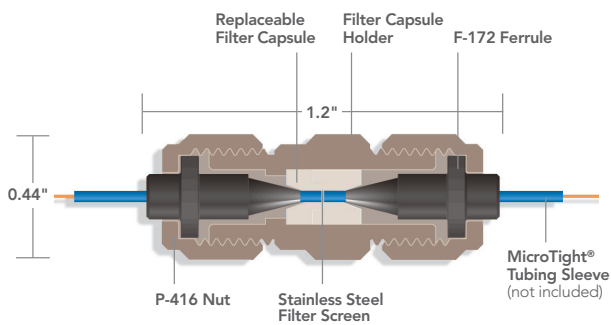

**M-530**  
Mini MicroFilter Assembly  
Includes indicated products

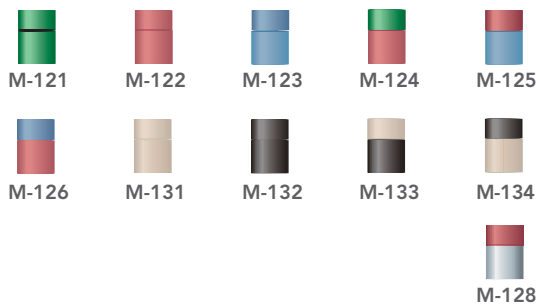
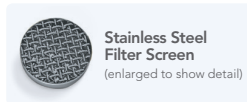

## Mini MicroFilters

- › Void volume as low as 10 nL!
- › Stainless steel and titanium filtration surfaces

Mini MicroFilter Assemblies filter effectively along capillary tubing flow paths with internal volumes low enough to ensure acceptable chromatographic results—even at nanoliter flow rates! They achieve this using replaceable NanoFilter™ capsules—some versions with a thin, stainless steel micro screen (0.25 mm thick x 1 mm diameter) and others with a miniscule sintered stainless steel or titanium frit disc (0.25 mm thick x 0.5 mm diameter). These encapsulated filters boast internal volumes as low as 85 nL with the micro-screen and 10 nL with the frit disc option!

Choose from 1 μm and 2 μm porosities. The micro-screen filter capsules have versions for connecting various tubing sizes in combination with our MicroTight Tubing Sleeves (page 6), or for direct connecting 360 μm and 1/32" (790 μm) OD tubing. The frit-disc filter capsules are designed specifically to direct connect 360 μm and 1/32" OD tubing.

### APPLICATION NOTE

The Mini MicroFilter and Inline MicroFilter can be used to pack capillary tubing. Simply position one of these filters on the effluent side of the capillary tubing, then slurry pack the capillary tubing. Once packed, place a filter at the head of the tube. This creates a reliable capillary column, without fusing the silica to make frits or pressing filter paper inside the capillary tube.

## Conductive Mini MicroFilter

- › 1 μm porosity with a void volume of 10 nL
- › For CEC and mass spectrometry applications

This product has the same design and function of the Mini MicroFilters above, with the added benefit of being conductive. Apply voltage to the stainless steel filter holder body for applications such as mass spectrometry and CEC analysis. The voltage is conducted through to the stainless steel portion of the NanoFilter Capsule and on to the fluid stream.

Each NanoFilter Capsule has an encased 1 μm stainless steel sintered frit disc with 10 nL total internal volume. The fittings included with the assembly allow easy connection of 360 μm OD capillary tubing.

### Filter Capsules for Mini MicroFilters

| Product | Porosity | Frit/Screen Material | For Mini MicroFilter Assembly | Ferrule | For use with Tubing OD Size | Void Volume |
|---------|----------|----------------------|-------------------------------|---------|-----------------------------|-------------|
| M-121   | 1 μm     | SST Screen           | M-531                         | F-172   | 70-520 μm*                  | 85 nL       |
| M-122   | 2 μm     | SST Screen           | M-530                         | F-172   | 70-520 μm*                  | 85 nL       |
| M-123   | 1 μm     | SST Screen           | M-533                         | F-152   | 360 μm                      | 85 nL       |
| M-124   | 2 μm     | SST Screen           | M-532                         | F-152   | 360 μm                      | 85 nL       |
| M-125   | 1 μm     | SST Frit             | M-537                         | F-152   | 360 μm                      | 10 nL       |
| M-126   | 1 μm     | Titanium Frit        | M-538                         | F-152   | 360 μm                      | 10 nL       |
| M-131   | 1 μm     | SST Screen           | M-543                         | F-112   | 1/32" (790 μm)              | 97 nL       |
| M-132   | 2 μm     | SST Screen           | M-542                         | F-112   | 1/32" (790 μm)              | 97 nL       |
| M-133   | 1 μm     | SST Frit             | M-547                         | F-112   | 1/32" (790 μm)              | 22 nL       |
| M-134   | 1 μm     | Titanium Frit        | M-548                         | F-112   | 1/32" (790 μm)              | 22 nL       |

\* Using MicroTight Tubing Sleeves (see page 5 and Product Listing Sheet).

### Conductive Mini MicroFilter

| Product | Porosity | Frit/Screen Material | For Mini MicroFilter Assembly | Ferrule | For use with Tubing OD Size | Void Volume |
|---------|----------|----------------------|-------------------------------|---------|-----------------------------|-------------|
| M-128   | 1 μm     | SST Screen           | M-534                         | F-152   | 360 μm*                     | 10 nL       |

## Inline MicroFilters

- › Void volume as low as 109 nL
- › 100% biocompatible PEEK™ polymer version available

Inline MicroFilters protect your column with 1.0 µm stainless steel micro screens (M-135) or 0.5 µm biocompatible PEEK polymer frits (M-520 or M-525), both incorporated into PEEK end fittings (five included). Each version features a 0.006" (150 µm) thru-hole and total theoretical void volumes of 240 nL and 109 nL, respectively. Also included are two F-125 MicroTight® Fittings (page 6), designed to work with our MicroTight Tubing Sleeves (page 5) and your capillary tubing (70-520 µm OD), or two F-126 fittings to connect 1/32" OD tubing into the M-525 inline filter. Replacement Filter End Fittings are available in convenient 10 packs.

## Precolumn MicroFilters

- › Only 0.5 µL void volume
- › Direct connects to most columns with 10-32 threads

With standard 10-32 male threads, these Precolumn MicroFilters direct connect into your microbore or analytical column. Total theoretical void volume, including frit volume, is only 0.5 µL, and the PEEK polymer tubing used in the assembly has a 0.005" (125 µm) ID, virtually eliminating any mixing. Two versions are available: one for standard 1/16" OD tubing, the other for capillary or fused silica tubing using our MicroTight Tubing Sleeves (page 5). These MicroFilter Assemblies come complete with 0.5 µm stainless steel or PEEK replacement frits.

*Please Note: The components of M-500 and M-510 Precolumn MicroFilters are not interchangeable with those of M-550 and M-560 versions (see Product Listing Sheet). They are tubing specific.*

### Inline & Precolumn Micro Filter Specifications

| Product                | Porosity | Frit/Screen Material | For use with Tubing OD Size | Void Volume |
|------------------------|----------|----------------------|-----------------------------|-------------|
| Inline MicroFilters    |          |                      |                             |             |
| M-520                  | 0.5 µm   | PEEK                 | 70-520 µm*                  | 109 nL      |
| M-135                  | 1.0 µm   | SST                  | 70-520 µm*                  | 240 nL      |
| M-525                  | 0.5 µm   | PEEK                 | 1/32" OD                    | 109 nL      |
| Precolumn MicroFilters |          |                      |                             |             |
| M-500                  | 0.5 µm   | SST                  | 70-520 µm*                  | 0.5 µL      |
| M-510                  | 0.5 µm   | PEEK                 | 70-520 µm*                  | 0.5 µL      |
| M-550                  | 0.5 µm   | SST                  | 1/16"                       | 0.5 µL      |
| M-560                  | 0.5 µm   | PEEK                 | 1/16"                       | 0.5 µL      |

\* Using MicroTight Tubing Sleeves (see page 5 and Product Listing Sheet).

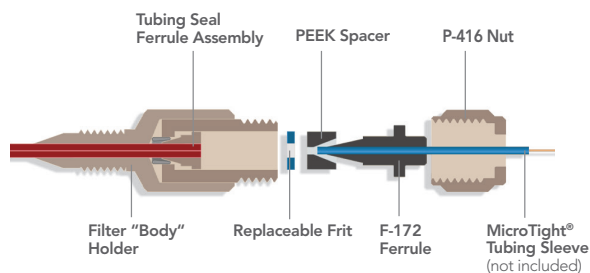
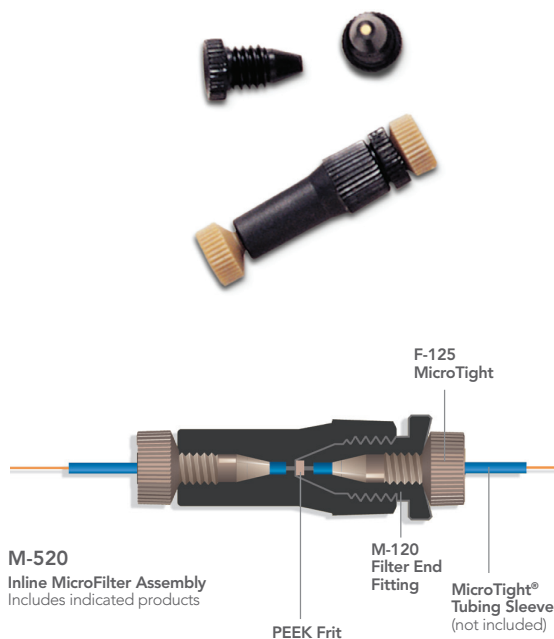

**M-500**  
Precolumn MicroFilter Assembly  
Includes indicated products

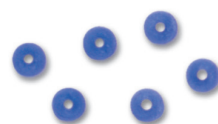



## Capillary/Microbore PEEK™ Tubing

- › ODs from 360 µm to 1/16"
- › IDs as small as 25 µm (0.001")

Capillary PEEK polymer tubing offers all the benefits of larger-sized PEEK tubing (strength, biocompatibility, chemical compatibility), while offering an excellent alternative to more traditional fused silica and stainless steel capillary tubing (see Application Note below). This tubing comes in 360 µm (0.0145") OD and 510 µm (0.020") OD.

Tolerances for our capillary PEEK tubing are ±0.0005" for both OD and ID of our 360 µm OD and ±0.001" for OD and ID of our 510 µm OD tubing. Both are rated to hold to 2,000 psi (138 bar).

We also manufacture 1/32" and 1/16" OD PEEK tubing with IDs in the microbore range (.0025"-.010"). Both ODs in this ID range are rated to hold to 5,000 psi, with tolerances as follows:

| Tubing Specifications |                 |                                                         |
|-----------------------|-----------------|---------------------------------------------------------|
| OD                    | OD/ID Tolerance | Pressure Rating                                         |
| 360 µm (.0145")       | ±0.0005"        | 2,000 psi (138 bar)–5,000 psi (345 bar) depending on ID |
| 510 µm (.020")        | ±0.001"         | 2,000 psi (138 bar)                                     |
| 1/32"                 | ±0.0005"        | 3,000 psi (207 bar)–5,000 psi (345 bar)                 |
| 1/16"                 | ±0.001"         | 7,000 psi (483 bar)                                     |

### APPLICATION NOTE

A study by a major pharmaceutical company reported significantly improved LC-MS chromatographic performance by switching the post-column transfer line from fused silica to PEEK polymer tubing. The switch dramatically reduced peak tailing and eliminated degradation of peak symmetry as the injection was reduced. For more information, download the "Improved LC-MS Results Study" on our website: [www.idex-hs.com/about/product\\_data\\_sheets.aspx](http://www.idex-hs.com/about/product_data_sheets.aspx)



## Teflon® FEP Capillary Tubing

- › Superb chemical compatibility

Ideal for applications where PEEK or fused silica are chemically incompatible, we offer 1/16" and 1/32" OD FEP capillary tubing in IDs as small as 0.003" (75 µm).

| Tubing Specifications |                 |                                                             |
|-----------------------|-----------------|-------------------------------------------------------------|
| OD                    | OD/ID Tolerance | Pressure Rating                                             |
| 1/16"                 | ±0.001"         | 4,000 psi (276 bar)                                         |
| 1/32"                 | ±0.0005"        | 2,500 psi (172 bar) to 4,000 psi (276 bar), depending on ID |

## 360 µm OD Teflon PFA HP Plus Tubing

- › Virtually contaminant free!
- › 50–150 µm IDs available

With purity in the parts per billion (perfect for medical, diagnostic, pharmaceutical, biotechnology and semiconductor applications), this virtually transparent tubing also withstands repeated flexing, and resists stress cracking when exposed to aggressive fluorosurfactants.

| Tubing Specifications |                 |                                                            |
|-----------------------|-----------------|------------------------------------------------------------|
| OD                    | OD/ID Tolerance | Pressure Rating                                            |
| 50 µm                 | ±0.0005"        | 1,750 psi (121 bar) to 3500 psi (241 bar), depending on ID |
| 150 µm                | ±0.0005"        | 1,750 psi (121 bar) to 3500 psi (241 bar), depending on ID |

To cut this tubing to the length you need, we highly recommend our A-350 Polymer Tubing Cutter (see facing page).

*Please Note: Once held in place by connecting fittings (such as featured on pages 2, 5 and 6), take care not to stretch the tubing, which will likely distort both the OD and ID.*

## Fused Silica Tubing

360 µm OD\* fused silica tubing (synthetic fused silica with polyimide coating) is offered in convenient 2 meter lengths. Choose from 20, 50, 75, 100 and 150 µm IDs.

The manufacturer rates this tubing for use up to 350° C. OD tolerance is ±10 µm. ID tolerances are ±2 µm for the 20 µm, ±3 µm for the 50 µm and 75 µm IDs and ±4 µm for the 100 µm and 150 µm IDs.

Connect this tubing to standard 10-32 ports using the NanoTight® Sleeves and your choice of NanoTight™ fittings (page 5). Several other parts in this brochure allow direct connection of 360 µm tubing.

\* Actual OD is 363 µm. Industry convention is to round to 360 µm. OD tolerance is ±12 µm.

## PEEKsil™ Tubing

- › Excellent chemical resistance and biocompatibility
- › Withstands up to 10,000 psi (690 bar)

Offered in 1/16" and 1/32" ODs and IDs from 25 to 300 µm, PEEKsil is PEEK™ polymer sheathed fused silica tubing. The PEEK sheathing is mechanically strong with ideal characteristics for sealing, whether using metal or polymer fittings. PEEKsil can directly replace conventional stainless steel or PEEK tubing in many analytical systems.

Like traditional fused silica tubing, PEEKsil has excellent chemical compatibility and extremely low absorption characteristics, especially when compared to stainless steel. The PEEK sheath/fused silica combination makes this tubing capable of withstanding up to 10,000 psi (690 bar).

PEEKsil is manufactured by SGE International Pty, Ltd. Their stated OD tolerance is ±20 µm for 1/32" OD and ± 30 µm for 1/16" OD. ID tolerances range from ±1 µm for 25 µm ID to ±5 µm for 200 µm and 300 µm IDs.

*Please Note: We do not recommend cutting this tubing. It should only be used in its available precut lengths because conventional cutters may cause damage.*

## Capillary/Microbore Stainless Steel Tubing

Seamless, precut stainless steel tubing with flat, burr-free ends for zero dead volume connections and improved chromatographic results. Our preparation and cleaning process ensures the tubing is truly ready-to-use. For details on this process, see our IDEX Health & Science catalog or [www.idex-hs.com](http://www.idex-hs.com).

For microscale applications, we offer 304 stainless steel tubing in 510 µm OD/125 µm ID, and 1/32" OD 316 stainless steel tubing in IDs as small as 0.004" (100 µm). Connect to standard 10-32 ports using appropriate NanoTight Sleeves and NanoTight nuts shown on page 5 and the product listing sheet.

## Tubing Cutters

For precise, burr-free cuts, use one of these reliable, easy-to-operate cutters.

|                                              |                           |
|----------------------------------------------|---------------------------|
| For capillary polymer tubing up to 1/32" OD: | <b>A-350</b>              |
| For 1/16" and 1/8" OD polymer tubing:        | <b>A-327</b> (not shown)  |
| For fused silica tubing (SGT Shortix™)       | <b>FS-315</b> (not shown) |

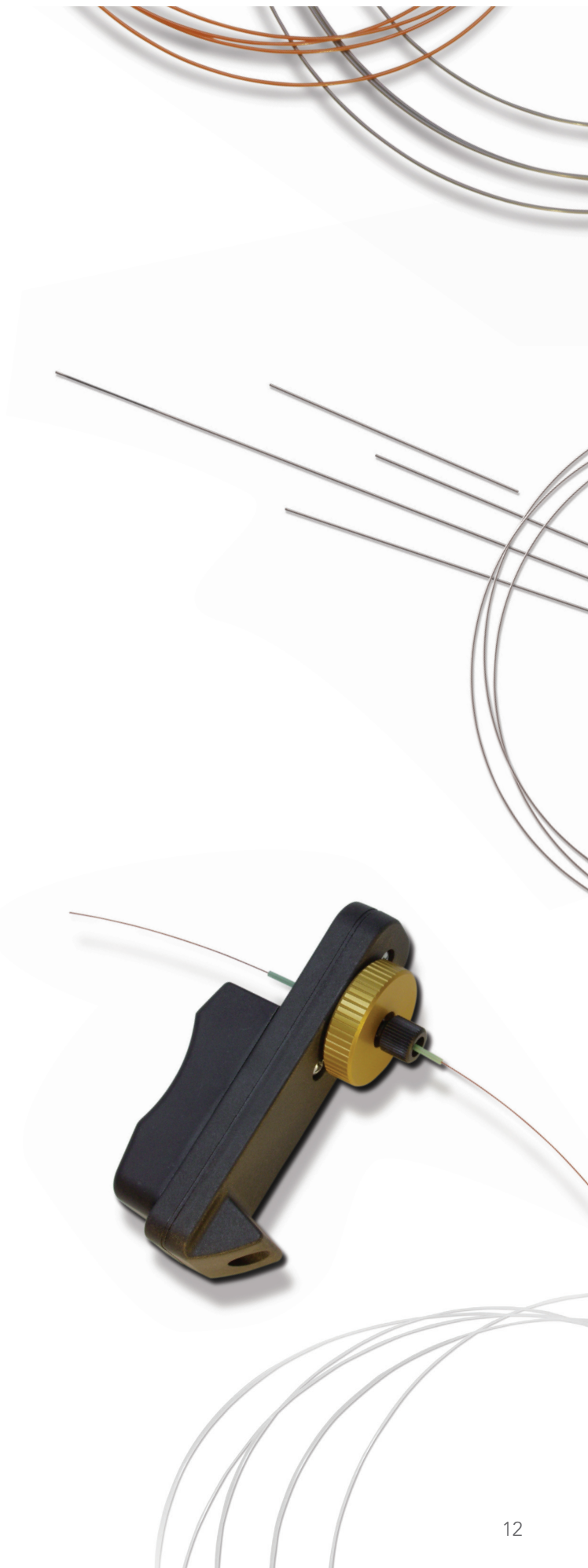

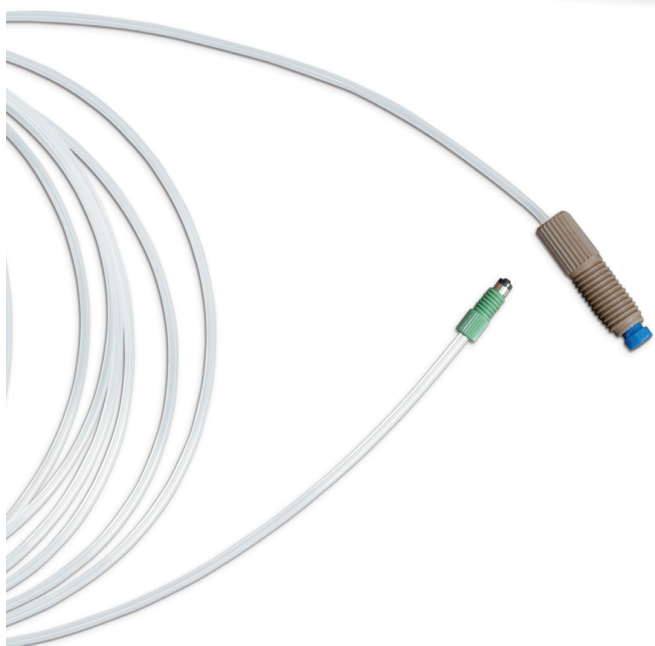

## OEM Custom Components

IDEX Health & Science manufactures custom micro- and nanoflow components to Original Equipment Manufacturers' specifications.

### Products

#### Valves

- › Fluid passage diameter down to 0.1 mm
- › Custom flow paths
- › Materials to meet pressure, chemical, and biocompatibility requirements
- › Custom labeling and pod color

#### Precision dispense pumps and HPLC/UHPLC pump components

- › Materials to meet pressure, chemical, and biocompatibility requirements
- › Custom for pump ball, piston, and seat configurations

#### Column Hardware

- › Custom IDs, ODs, and lengths
- › End fittings, finishes, and labeling to specification

#### Nanoliter liquid handling products

- › Customizable number of sampling tips as well as sampling speed and flow rate

#### Tubing, fittings, and assemblies

- › Wide array of tubing materials including polymers, stainless steel, and titanium
- › Custom IDs, ODs, lengths, and unique bends
- › Fittings to meet pressure, chemical, and biocompatibility requirements
- › Labeling, color coding and/or bundling to meet your needs

### Capabilities

Our molding, machining and extrusion capabilities allow us to create some of the most exacting micro- and nanoflow fluid transfer components and manifolds possible using the most advanced materials available.

#### Molding

- › Precision injection molding of tight-tolerance configurations
- › Insert molding options
- › Microprocessor controlled molding machines

#### Extrusion

- › ODs from 360  $\mu\text{m}$
- › Wall thickness from 38.1  $\mu\text{m}$
- › IDs as small as 50  $\mu\text{m}$
- › OD/ID tolerances as low as 12.5  $\mu\text{m}$
- › Multilumen capabilities and custom compounding

#### Machining

- › Holes as small as 0.004" (102  $\mu\text{m}$ ) in plastics and 0.007" (178  $\mu\text{m}$ ) in metals
- › Tolerances down to less than 0.0001" (2.54  $\mu\text{m}$ )

#### Integrated Assemblies

Single-point-of-contact access to the combined fluidics expertise and products of IDEX Health & Science, providing a complete and easy integrated solution to your application challenges.

## Polymer Information

The chart below encapsulates the essential characteristics of polymers used to manufacture many of the components featured in this brochure. For more extensive data on properties and compatibility, please visit the Materials Guide on our website: [www.idex-hs.com/materials/materials\\_guide.aspx](http://www.idex-hs.com/materials/materials_guide.aspx).

**PCTFE (polychloro-trifluoroethylene).** PCTFE has excellent chemical resistance. In general, only THF and a few halogenated solvents will react with it. This resilient fluoropolymer is ideal for fittings and sealing surfaces, and is generally used for high-pressure fittings and frit containment rings.

**PEEK Polyetheretherketone.** PEEK polymer has excellent chemical resistance to virtually all commonly used solvents. However, the following solvents are usually not recommended for use with PEEK: nitric acid; sulfuric acid; halogenated acids, such as hydrofluoric acid and hydrobromic acid (hydrochloric acid is approved for use in most applications); and pure halogenated gases. Additionally, due to a swelling effect, be cautious in using the following solvents with PEEK tubing: methylene chloride, THF, and DMSO<sup>†</sup>. PEEK polymer is used extensively throughout the Upchurch Scientific product line to manufacture tubing, fittings, filters, and other accessories.

**Teflon® FEP (fluorinated ethylene-propylene) and PFA (perfluoroalkoxy alkane).** Both forms of Teflon are virtually inert to all chemicals used in HPLC. However, because of their relative softness and low durability, Teflon polymers are generally used for low pressure applications. Teflon is utilized in the Upchurch Scientific® product line for low pressure fittings, tubing, and accessories. Choose PFA for high purity applications, or choose FEP for general, low pressure applications.

**ETFE (ethylene-tetrafluoroethylene).** As a member of the fluoropolymer family, ETFE has excellent solvent resistance. Its relatively high tensile strength makes it ideal for demanding sealing applications. While most commonly used solvents do not interact with ETFE, take caution when using some chlorinated chemicals. ETFE is used extensively in the Upchurch Scientific product line to manufacture low pressure fittings, tubing, and accessories.

## Technical Resources

IDEX Health & Science offers a number of technical resources to help solve your fluid transfer problems— including micro-nanoscale applications.

- › Support Center at [www.idex-hs.com](http://www.idex-hs.com), which features the HPLC Center, Fittings Primer, Materials Guide, Conversion Tools, Standard Port Drawings and an Information Exchange.
- › Technical Reference Chapter in the IDEX Health & Science Catalog, which includes conversion tables and a Fittings Primer.
- › All About Fittings by John Batts, IV. In this 64-page booklet Batts unravels the mysteries of plumbing HPLC and other fluid transfer applications.



## Our Distributors

IDEX Health & Science has established relationships with a large, global network of Distributors, many of whom can offer product support and assistance we cannot, including:

- › Carrying local inventory of commonly-ordered items
- › Understanding YOUR working environment and requirements
- › Providing technical application assistance
- › Answering questions regarding new and existing products
- › Complete availability during your time zone business hours
- › Personal visits as required
- › Access to complementary product lines

We have come to rely on our authorized Distributors to provide value-added service to end-users of our products. While we are happy to take your order directly, we encourage you to contact your local Distributor!

|                                              | PCTFE       | PEEK <sup>†</sup> | Teflon <sup>®1</sup> |            | ETFE        |
|----------------------------------------------|-------------|-------------------|----------------------|------------|-------------|
| <b>Chemical Family</b>                       |             |                   |                      |            |             |
| Aromatics                                    | R           | R                 | R                    |            | R           |
| Chlorinated                                  | M           | M                 | R                    |            | R           |
| Ketones                                      | R           | R                 | R                    |            | R           |
| Aldehydes                                    | R           | R                 | R                    |            | R           |
| Ethers                                       | M           | M                 | R                    |            | R           |
| Amines                                       | R           | R                 | R                    |            | M           |
| Aliphatic Solutions                          | R           | R                 | R                    |            | R           |
| Organic Acids                                | R           | M                 | R                    |            | R           |
| Inorganic Acids                              | R           | M                 | R                    |            | M           |
| Bases                                        | R           | R                 | R                    |            | R           |
| Sulfonated Compounds                         | R           | M                 | R                    |            | R           |
| <b>Thread Strength*</b>                      | <b>Good</b> | <b>Excellent</b>  | <b>Good</b>          |            | <b>Good</b> |
| <b>Max. Recommended Operating Temp. (°C)</b> |             |                   | <b>FEP</b>           | <b>PFA</b> |             |
| Fittings                                     | 80          | 125**             | N/A                  | 80         | 80          |
| Tubing                                       | N/A         | 100**             | 50                   | 80         | 80          |

<sup>1</sup> While the chemical compatibility of FEP & PFA Teflon is virtually identical, please note the temperature limit differences.

R Recommended

M Some solvents in this category are satisfactory, others are not. In addition, maximum concentration can vary with the specific product type and chemical.

Please contact Upchurch Scientific for further information.

NR Chemicals in this category are generally not recommended for use with this polymer.

N/A Information not available.

\* Shear Strength

\*\* In some cases, PEEK fittings can be used to 150° C. Please contact Upchurch Scientific for specific information.

† In some circumstances, acetonitrile has been reported to swell and occasionally burst PEEK tubing. Exercise caution when using high concentrations of acetonitrile at or near the maximum pressure of this tubing.



©2014 IDEX Health & Science LLC. IDX2047/09.2014

**For ordering and technical support, please contact:**

**North America** [CustomerService.hs@idexcorp.com](mailto:CustomerService.hs@idexcorp.com) | +1 800 426 0191 | +1 360 679 2528  
**Europe** [CustomerService.hsEurope@idexcorp.com](mailto:CustomerService.hsEurope@idexcorp.com) | +49 1801 808 800 | +49 9377 9203-0  
**Asia** [CustomerService.hsAsia@idexcorp.com](mailto:CustomerService.hsAsia@idexcorp.com) | **North Asia** +86 10 6566 9090 | +86 21 5241 5599  
**South Asia** +91 22 66 43 55 50 | **Southeast Asia & Oceania** +65 6763 6633 | **Japan** +81 48 240 5750