

sample storage | 562-607

Everything you need to protect and track your samples.

Whether you're storing just a few cryogenic samples or thousands of 2D barcoded specimens in a biobank, we have a Thermo Scientific tube for you – plus all the accessories and equipment you need to ensure efficient sample preservation, tracking and identification.

Thermo Scientific Nalgene and Nunc cryogenic tubes are ideally suited for research storage of high-value materials, tissue and blood specimens, and general purpose cryopreservation. Nalgene™ tubes are certified RNase- and DNase-free and sterile to SAL 10^{-6} , are non-cytotoxic and non-pyrogenic, and carry CE marking. The Nunc™ cryogenic line features both internal- and external-thread tubes.

For the next level of storage and tracking, look to **Thermo Scientific 2D barcoded tubes**. Nunc Cryobank™ tubes have a high-contrast, permanent 2D barcode etched into the bottom of each. Packaged in an ANSI microplate footprint rack, Cryobank tubes are compatible with decapping and capping equipment and are available in volumes up to 5.0 mL.

Thermo Scientific Matrix 2D barcoded tubes feature permanent, etched 2D codes and unique rack design, ideal for automation and sample tracking. Matrix 2D coded tubes are perfect for small or large-scale sample storage and are available in volumes from 0.5 to 12 mL. To meet laboratory throughput needs, Thermo Scientific VisionMate 2D barcode readers complement our line of storage tubes. Rely on our 8-channel Capper/Decapper for speedy tube handling, or our Thermo Scientific Capit-All automated capper for higher throughput full-rack capping and decapping.

- ▶ For additional information on our sample storage products, visit: www.thermoscientific.com/samplestorage



protect
with
confidence

► Sample Storage Table of Contents

Thermo Scientific Products	Page
Nalgene General Long-term Storage Cryogenic Tubes	565
Nalgene General Long-term Storage Cryogenic Tube Accessories	566
Nunc Biobanking and Cell Culture	567
Nunc Biobanking and Cell Culture Cryogenic Tubes	568
Nunc Biobanking and Cell Culture Cryogenic Tube Accessories	569
Nunc General Long-term Storage Tubes	570
Linear Barcoded Tubes	571
Dense Storage Options	572
Nalgene and Nunc Labels and Pens	573
Storage Tube Protection	574
Storage Canes	575
Nalgene Mr. Frosty Freezing Container	576
Cryoboxes	577
Cryobox Freezer Racks	578
Benchtop Coolers	579
Benchtop Dewars	581
Matrix 2D Barcoded ScrewTop Storage Tubes and Caps	583
Nunc Cryobank Tube Systems	588
Nunc Cryobank and Vial Systems	590
Matrix 2D Barcoded Storage Tubes	591
Matrix Blank and Alphanumeric Storage Tubes	594
Matrix SeptraSeal and DuraSeal Capping Systems	596
ID Scribe Labware Identifier	598
Capit-All and Capit-All IS Screw Cap Tube Capper/Decapper	600
8-Channel Screw Cap Decapper	602
VisionMate High Speed 2D Barcode Reader	603
VisionMate Wireless 2D Barcode Reader	604
VisionTracker Storage Tracking Database Software	605
VisionMate SR Single Rack 2D Barcode Reader	606
VisionMate ST Single-Tube 2D Barcode Reader	607

► Thermo Scientific Nalgene General Long-term Storage Cryogenic Tubes



Nalgene™ Cryogenic Tubes are externally-threaded storage tubes ideally suited for research and general laboratory storage of high-value and genomic materials down to vapor phase liquid nitrogen temperatures.

details

- Large writing areas accommodate more written sample information and graduations for easy visual volume assessment
- Non-cytotoxic raw materials for added sample security and tubes certified free of DNase and RNase for genomic applications
- External threading enhances aseptic technique
- Certified SAL to 10^{-6} for the highest sterility assurance available
- Suitable for storage from general cold storage refrigeration (+4°C) down to the vapor phase of liquid nitrogen
- System 100 Tubes offer a more dense storage option (10 x 10) to save precious storage space
- Self-standing tubes for ease of use on the benchtop
- Blank, non-sterile and uncapped tubes available in bulk for less demanding applications

Certifications: CE Marked for storage of diagnostic samples in the EU.

Notes: Do not store in the liquid phase of nitrogen without CryoFlex tubing.

Nalgene General Long-term Storage Cryogenic Tubes

Cat. No.	Size, mL	Dimensions, H x O.D., mm (in.)	Thread Style	Closure Material	Bottom Style	Anti-Rotation Base	Self-Standing	Writing Area and Graduations	Sterile	Vapor LN ² (to -150°C)	DNase/RNase Free	No. per Pack	No. per Case
5000-1012	1	38 x 12 (1.496 x 0.472)	External	PP	Conical	Yes	Yes	Yes	Yes	Yes	Yes	25	500
5000-0012	1.2	38.1 x 13.5 (1.5 x 0.531)	External	PE	Conical	Yes	Yes	Yes	Yes	Yes	Yes	25	500
5012-0012	1.2	38.1 x 13.5 (1.5 x 0.531)	External	PE	Conical	Yes	Yes	No	Yes	Yes	Yes		1000
5011-0012	1.2	38.1 x 13.5 (1.5 x 0.531)	External	PE	Conical	Yes	Yes	No	Yes	Yes	No		1000
5000-1020	1.5	48 x 12 (1.89 x 0.472)	External	PP	Conical	Yes	Yes	Yes	Yes	Yes	Yes	25	500
5000-0020	2	48.3 x 13.5 (1.902 x 0.531)	External	PE	Conical	Yes	Yes	Yes	Yes	Yes	Yes	25	500
5012-0020	2	48.3 x 13.5 (1.902 x 0.531)	External	PE	Conical	Yes	Yes	No	Yes	Yes	Yes		1000
5011-0020	2	48.3x13.5 (1.902 x 0.531)	External	PE	Conical	Yes	Yes	No	Yes	Yes	No		1000
5000-0050	5	92 x 13.5 (3.622 x 0.531)	External	PE	Conical	Yes	Yes	Yes	Yes	Yes	Yes	10	250
5005-0015	15	33 x 47 (1.299 x 1.850)	External	PE	Flat	No	Yes	No	Yes	No	No	5	75

► Thermo Scientific Nalgene General Long-term Storage Cryogenic Tube Accessories



Color coders



Benchtop cryogenic tube holder

Nalgene™ Cryogenic Tube Accessories are specifically designed to enhance use of the Nalgene Cryogenic Tube products, including color coders for individual tube identification and benchtop tube holders for single-handed capping and decapping.

details

- Polystyrene coders snap into the caps of Nalgene Cryogenic Tubes for easy sample identification
- Polycarbonate Benchtop Cryogenic Tube Holder has anti-rotation feature for one-handed capping and decapping

Nalgene General Long-term Storage Cryogenic Tube Accessories

Cat. No.	Description	Color	Array	Anti-Rotation	No. per Pack	No. per Case
5045-0000	Color coder	White	n/a	n/a	100	500
5045-0002	Color coder	Yellow	n/a	n/a	100	500
5045-0003	Color coder	Blue	n/a	n/a	100	500
5045-0004	Color coder	Green	n/a	n/a	100	500
5045-0005	Color coder	Red	n/a	n/a	100	500
5030-0510	Benchtop Cryogenic Tube Holder	White	5 x 10	Yes	1	4
5030-0505	Benchtop Cryogenic Tube Holder	Blue	5 x 5	Yes	1	4

► Thermo Scientific Nunc Biobanking and Cell Culture



Nunc™ Cryotubes and accessories are designed to work together and provide the best solutions for the most trusted sample storage applications, such as highly-regulated applications, irreplaceable high-value content storage and tissue, cell, blood or other materials for biobanking.

details

- Non-cytotoxic, non-mutagenic raw materials and pyrogen-free IVD compatible tubes for added sample security
- External or internally threaded options available
- Tubes certified DNase- and RNase-free for genomic applications
- Certified SAL to 10⁻⁶ for the highest sterility assurance available
- Suitable for storage from general cold storage refrigeration (+4°C) down to the vapor phase of liquid nitrogen
- Bulk, uncapped, non-sterile versions available for less demanding applications
- Self-standing, anti-rotation and round bottom options available to meet any requirement

Compliance: CE Marked for storage of diagnostic samples in the EU. Compliant with IATA for shipping.

Notes: Do not store in the liquid phase of nitrogen without CryoFlex tubing.

Nunc Biobanking and Cell Culture Cryogenic Tubes

Cat. No.	Size, mL	Dimensions, H x O.D., mm (in.)	Thread Style	Closure Material	Bottom Style	Anti-Rotation Base	Self-Standing	Writing Area and Graduations	Sterile	Vapor LN ² (to -150°C)	DNase/RNase Free	No. per Pack	No. per Carton	No. per Case
374080	0.5	35 x 8.8 (1.378 x 0.346)	Internal	PP	Conical	Yes	Yes	No	Yes	Yes	Yes	169		845
374081	1	48.5 x 8.8 (1.909 x 0.346)	Internal	PP	Conical	Yes	Yes	No	Yes	Yes	Yes	169		845
375353	1	41 x 12.5 (1.614 x 0.492)	External	PE	Conical	Yes	Yes	Yes	Yes	Yes	Yes	50	500	2000
375299	1	30 x 12.4 (1.181 x 0.492)	External	PE	Round	No	No	Yes	Yes	No	Yes	50	500	2000
347597	1	41 x 12.4 (1.614 x 0.488)	External	PE	Conical	Yes	Yes	No	Yes	Yes	Yes	50	500	2000
377224	1	42 x 12.5 (1.654 x 0.492)	Internal	PP	Conical	Yes	Yes	Yes	Yes	Yes	Yes	50	500	2000
366656	1	42 x 12.5 (1.654 x 0.492)	Internal	PP	Conical	Yes	Yes	Yes	Yes	Yes	Yes	50	500	2000
375418	1.8	48 x 12.5 (1.890 x 0.492)	External	PE	Round	Yes	Yes	Yes	Yes	Yes	Yes	50	450	1800
340711	1.8	44 x 12.4 (1.732 x 0.488)	External	PE	Round	No	No	Yes	Yes	No	Yes	50	500	2000
347627	1.8	48 x 12.5 (1.890 x 0.492)	External	PE	Round	Yes	Yes	No	Yes	Yes	Yes	50	450	1800
377267	1.8	49 x 12.5 (1.929 x 0.492)	Internal	PP	Round	Yes	Yes	Yes	Yes	Yes	Yes	50	450	1800
368632	1.8	49 x 12.5 (1.929 x 0.492)	Internal	PP	Round	Yes	Yes	Yes	Yes	Yes	Yes	50	450	1800



► Thermo Scientific Nunc Biobanking and Cell Culture Cryogenic Tubes continued

Nunc Biobanking and Cell Culture Cryogenic Tubes

Cat. No.	Size, mL	Dimensions, H x O.D., mm (in.)	Thread Style	Closure Material	Bottom Style	Anti-Rotation Base	Self-Standing	Writing Area and Graduations	Sterile	Vapor LN ² (to -150°C)	DNase/RNase Free	No. per Pack	No. per Carton	No. per Case
363401	1.8	48 x 12.5 (1.890 x 0.492)	Internal	PP	Round	No	No	Yes	Yes	Yes	Yes	50	500	2000
351934	1.8	48 x 1 2.5 (1.890 x 0.492)	Internal, NC	n/a	Round	No	No	Yes	No	Yes	Yes	250		2500
379189	3.6	72 x 12.5 (2.835 x 0.492)	Internal	PP	Round	Yes	Yes	Yes	Yes	Yes	Yes	50	400	1600
366524	3.6	70 x 12.5 (2.756 x 0.492)	Internal	PP	Round	No	No	Yes	Yes	Yes	Yes	50	400	1600
367997	3.6	70 x 12.5 (2.756 x 0.492)	Internal, NC	n/a	Round	No	No	Yes	No	Yes	Yes	250		1500
337516	4.5	91 x 12.5 (3.583 x 0.492)	External	PE	Round	Yes	Yes	Yes	Yes	Yes	Yes	50	300	1200
347643	4.5	91 x 12.5 (3.583 x 0.492)	External	PE	Round	Yes	Yes	No	Yes	Yes	Yes	50	300	1200
379146	4.5	92 x 12.5 (3.622 x 0.492)	Internal	PP	Round	Yes	Yes	Yes	Yes	Yes	Yes	50	300	1200
363452	4.5	92 x 12.5 (3.622 x 0.492)	Internal	PP	Round	No	No	Yes	Yes	Yes	Yes	50	300	1200

► Thermo Scientific Nunc Biobanking and Cell Culture Cryogenic Tube Accessories



Color coders

Nunc™ Cryotube Accessories line includes items to make the tubes easier to use and more flexible for your laboratory needs.

details

- Polycarbonate Color Coders snap into caps of Nunc Cryotubes for easy identification of samples
- Color coders compatible with Nunc Cryobank 2.0 and 5.0 mL caps
- Polyphenylene oxide benchtop tube holders are autoclavable for ease of sterilization and include anti-rotation features for one-handed capping and decapping

Nunc Biobanking and Cell Culture Cryogenic Tube Accessories

Cat. No.	Description	Color	Array	Anti-Rotation	No. per Pack	No. per Case
375930	Color Coder	Assorted	n/a	n/a	500	2000
354755	Color Coder	White	n/a	n/a	500	2000
354879	Color Coder	Blue	n/a	n/a	500	2000
354968	Color Coder	Red	n/a	n/a	500	2000
355018	Color Coder	Green	n/a	n/a	500	2000
355077	Color Coder	Yellow	n/a	n/a	500	2000
355158	Color Coder	Orange	n/a	n/a	500	2000
375868	Color Coder	Brown	n/a	n/a	500	2000
375884	Color Coder	Pink	n/a	n/a	500	2000
375906	Color Coder	Gray	n/a	n/a	500	2000
375922	Color Coder	Purple	n/a	n/a	500	2000
376589	Benchtop Cryogenic Tube Holder	Blue	4 x 10	Yes	1	15



Benchtop cryogenic tube holder

► Thermo Scientific Nunc General Long-term Storage Tubes



Nunc™ Stor-It™ tubes are an economical choice for samples.

Starfoot vial fits into grooves of the CryoTube Rack (Cat. No. 376589), which allows one-hand operation.

details

- Caps and tubes packaged separately to save handling time
- Tubes are non-sterile
- Economical choice for less demanding applications

Nunc General Long-term Storage Tubes

Cat. No.	Size, mL	Dimensions, H x O.D., mm (in.)	Thread Style	Closure Material	Bottom Style	Anti-Rotation	Self-Standing	Writing Area and Graduations	Sterile	Vapor LN ² (to -150°C)	DNase/RNase Free	No. per Pack	No. per Carton	No. per Case
347651	1	41 x 12.5 (1.614 x 0.492)	External	PE	Conical	Yes	Yes	Yes	No	Yes	No	50	500	2000
347910	1	41 x 12.5 (1.614 x 0.492)	External	PE	Conical	Yes	Yes	No	No	Yes	No	50	500	2000
347783	1.8	48 x 12.5 (1.890 x 0.492)	External	PE	Round	Yes	Yes	Yes	No	Yes	No	50	450	1800
347791	4.5	91 x 12.5 (3.583 x 0.492)	External	PE	Round	Yes	Yes	Yes	No	Yes	No	50	300	1200

▶ Thermo Scientific Linear Barcoded Tubes



Nalgene barcoded tubes



Nunc barcoded tubes

Nunc™ and Nalgene™ Cryotubes with directly-printed barcodes are more robust than labels and ideal for easy sample inventory.

Choose from available non-custom options below or call for customized options in a wide range of choices of code type, length and format.

details

- Black barcode directly printed onto white background for high contrast and readability even in high-frost conditions
- Human readable code below the barcode for easy visual identification without a barcode reader
- Barcodes resistant to IPA, DMSO, 5% bleach, 10% acetic acid and 10% NaOH
- Non-cytotoxic raw materials for added sample security and tubes certified free of DNase and RNase for genomic applications
- External or internally threading options available
- Certified SAL to 10⁻⁶ for the highest sterility assurance available
- Suitable for storage from general cold storage refrigeration (+4°C) down to the vapor phase of liquid nitrogen

Compliance: CE Marked for storage of diagnostic samples in the EU. Nunc tubes compliant with IATA for shipping.

Notes: Do not store in the liquid phase of nitrogen without CryoFlex tubing.

Linear Barcoded Tubes

Cat. No.	Size, mL	Dimensions, H x O.D., mm (in.)	Thread Style	Closure Material	Bottom Style	Anti-Rotation	Self-Standing	Writing Area and Graduations	Sterile	Vapor LN ² (to -150°C)	DNase/RNase Free	No. per Pack	No. per Carton	No. per Case
5001-0012	1.2	38.1 x 13.5 (1.5 x 0.531)	External	PE	Conical	Yes	Yes	No	Yes	Yes	Yes	20		500
5001-0050	2	92 x 13.5 (3.622 x 0.531)	External	PE	Conical	Yes	Yes	No	Yes	Yes	Yes	25		250
5001-1020	5	48 x 12 (1.890 x 0.472)	External	PP	Conical	Yes	Yes	No	Yes	Yes	Yes	20		500
5001-0020	1.5	48.3 x 13.5 (1.902 x 0.531)	External	PE	Conical	Yes	Yes	No	Yes	Yes	Yes	20		500
373530	1.8	48 x 12.5 (1.890 x 0.492)	Internal	PP	Round	Yes	Yes	No	No	Yes	Yes	50	450	1800
373530	1.8	48 x 12.5 (1.890 x 0.492)	Internal	PP	Round	Yes	Yes	No	Yes	Yes	Yes	50	450	1800

► Thermo Scientific Dense Storage Options



Dense low temperature storage



Fits in racks you already own

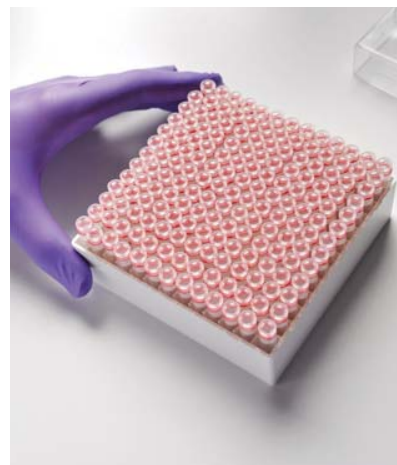

169 tubes fit in the same footprint currently storing 81 or 100 tubes

The Dense Low Temperature Storage format uses standard CryoBox sizes that work with the freezer racks you currently own.

By using standard boxes with 13 x 13 tube separators, up to 169- 1 mL tubes fit in a standard size CryoBox – effectively doubling your capacity and cutting storage costs by 50%.

details

- Available in economical cardboard or long-lasting plastic cryobox options
- Fits up to 169- 1 mL Cryobank tubes for the most dense storage available
- See Cryobank product section for details about the tubes that fit in these cryoboxes

Dense Storage Options

Cat. No.	Description	Capacity, No. of Tubes	Dimensions L x H x W, mm (in.)	No. per Pack	No. per Case
5050-0169	CryoBox, PC, white with clear lid	169	133 x 133 x 52 (5-1/4 x 5-1/4 x 2)	4	24
369640	Storage Box, cardboard, white	169	132 x 132 x 51 (5-1/5 x 5-1/5 x 2)	4	24
5050-0001	CryoBox, undivided, PC, white with clear lid	n/a	133 x 133 x 52 (5-1/4 x 5-1/4 x 2)	4	24
374001	Storage Box replacement divider	169	n/a	4	24
369678	Picker Pen for CryoBank Cap	n/a	n/a	1	24



► Thermo Scientific Nalgene and Nunc Labels and Pens



Nalgene pens

Nalgene™ and Nunc™ Labels and Markers are designed for permanent identification of samples and storage boxes.

details

- Cloth labels accept markers or ballpoint pen and are specifically designed for use at ultra-low temperatures, adhering to plastic and cardboard without shrinking or peeling
- Nunc and Nalgene cryoware markers come in a variety of colors for permanent handwritten identification of samples
- Use these markers by hand, or for higher throughput use them in the ID Scribe



Nunc pens

Labels and Pens

Cat. No.	Dimensions, H x W, mm (in.)	Colors	No. per Pack	No. per Case
5040-0002	25 x 50 (1 x 2)	white	200	2000
6313-0010	n/a	1 each – red, blue, green, black	4	24
339993	n/a	1 each – red, blue, green, black	4	24
343850	n/a	black	1	10

► Thermo Scientific Storage Tube Protection



Nunc CryoFlex tubing

Protect your cryogenic tubes with Nunc™ Cryoflex tubing or Cryosleeves and our Nunc™ Mini-boxes for shipping or handling.

details

- Heat shrink/pinch each end of the Nunc Cryoflex tubing around cryostorage tubes to prevent leakage of liquid nitrogen into the tubes during storage
- Transparent Nunc Cryosleeve tubing fits any Nunc or Nalgene cane and provides extra security during handling and submersion of tubes into the liquid phase without the tubes touching the liquid nitrogen
- Nunc Mini-boxes are ideal for storing small quantities of samples for shipping
- Friction-fit lid and durable high-impact polystyrene construction to protect samples
- Cryoflex tubing is compatible with Nalgene and Nunc cryo tubes and all Thermo Scientific 2D coded tubes

Storage Tube Protection

No.	Description	Dimensions L x H x W /I.D., mm (in.)	Capacity, No. of Tubes	No. per Pack	No. per Case
358	CryoFlex Tube Wrap	500 x n/a x 14 (19.685 x n/a x 0.551)	Varies	15	30
3-0001	CryoSleeve Tubing	100 x n/a x 14 (3.937 x n/a x 0.551)	Varies	12	48
479	CryoTube Mini Box	69.7 x 55.7 x 17.2 (2.744 x 2.193 x 0.677)	5		350
592	CryoTube Mini Box	69.3 x 54.4 x 29.1 (2.728 x 2.142 x 1.456)	10		250



Nunc Cryotube sealed in CryoFlex tubing



Nunc Cryotube Mini-boxes



Nalgene CryoSleeve tubing



► Thermo Scientific Storage Canes

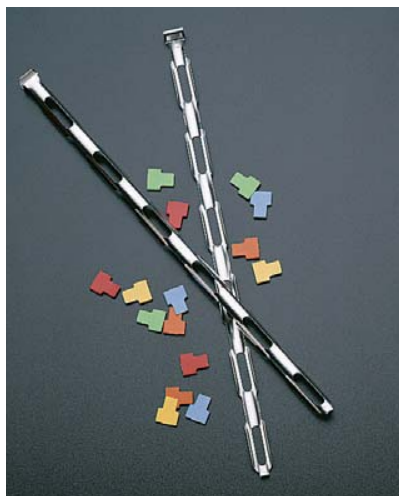

Storage canes accommodate a variety of tube sizes and types; available standard or stepped for optimal organization of your samples.

details

- For storage of Nalgene™ or Nunc™ cryostorage tubes
- Compatible with tubes protected with Cryoflex tubing
- Available color coders attach to the end of the cane and can be written on for quick identification and inventory management

Storage Canes

Cat. No.	Description	Design	Length, mm (in.)	No. per Pack	No. per Case
378441	Nunc Storage Cane, aluminum	Standard	290 (11.3125)		50
5015-0001	Nalgene CryoCane, aluminum	Stepped	290 (11.3125)	12	48
5015-0002	Nalgene CryoCane, aluminum	Stepped	300 (11.8125)	12	48
DS5020-0000	Nalgene Storage Cane Coders, aluminum, white, 100/case	n/a	n/a		100

► Thermo Scientific Nalgene Mr. Frosty Freezing Container



Mr. Frosty available in three sizes

Nalgene™ Mr. Frosty containers provide a simple-to-use system designed to achieve a rate of cooling very close to $-1^{\circ}\text{C}/\text{minute}$, the optimal rate for cell preservation.

details

- Three sizes accommodate volume range from 1-5 mL
- Holds 12 to 18 tubes and has profile height of 86 or 151 mm (3.4375 or 5.3125 in.), saving precious freezer space during the cooling process
- Screw top lid secures samples inside in the event of accidental container tipping
- Eliminates unreliable, improvised foam container devices
- Easy to use – requires only 100% isopropyl alcohol and a mechanical freezer
- Tubes do not contact alcohol; no wicking, label removal or compromise of hand printing

Requires: Isopropyl alcohol and a mechanical freezer.



Instructions conveniently printed on side

Mr. Frosty Freezing Container

Cat. No.	Tube Compatibility, mL	Capacity, No. of Tubes	Dimensions H x O.D., mm (in.)	Color	No. per Case
5100-0001	1.0-2.0	18	86 x 117 (3-7/16 x 4-5/8)	clear / blue lid	1
5100-0036	3.6	12	151 x 117 (6 x 4-5/8)	clear / blue lid	1
5100-0050	4.5-5.0	12	151 x 117 (6 x 4-5/8)	clear / blue lid	1



Mr. Frosty insert keeps tubes from contacting alcohol

► Thermo Scientific Cryoboxes

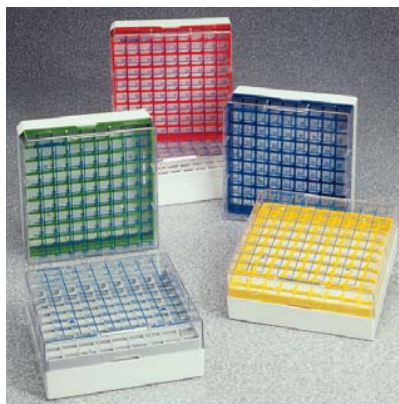

Nalgene colored cryoboxes for up to 81 tubes



Nalgene cryoboxes for 25 to 81 tubes

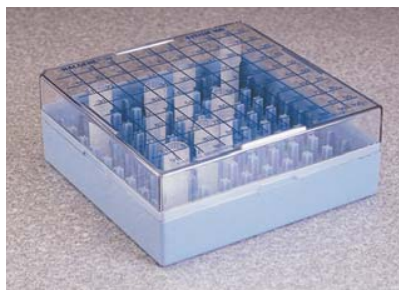

Nalgene System 100 cryobox for up to 100 tubes



Nunc cardboard cryoboxes

CryoBoxes from economical chipboard boxes to break-resistant, durable polycarbonate boxes.

details

- Durable plastic cryoboxes for short- or long-term storage
- Keyed lid on plastic cryoboxes prevent misalignment
- Printed grid for easy inventory management
- Plastic boxes autoclavable for decontamination and usable at temperature range from -196°C to +121°C
- Economical chipboard cryoboxes for short-term storage
- Chipboard boxes include dividers
- Vent in base for good drainage and air circulation
- Available with dividers from 25 to 169 tube storage
- See Dense Storage Options for details on 169-tube cryoboxes

Cryoboxes

Cat. No.	Color	Capacity, No. of Tubes	Dimensions, L x W x H, mm (in.)	No. per Pack	No. per Case
867013-0240	Red	81	133 x 133 x 52 (5.25 x 5.25 x 2.13)	4	24
867013-0241	Yellow	81	133 x 133 x 52 (5.1 x 5.1 x 2)	4	24
867013-0242	Green	81	133 x 133 x 52 (5.1 x 5.1 x 2)	4	24
867013-0243	Blue	81	133 x 133 x 52 (5.1 x 5.1 x 2)	4	24
867013-0244	Gray	81	133 x 133 x 52 (5.1 x 5.1 x 2)	4	24
867013-0245	Assorted	81	133 x 133 x 52 (5.1 x 5.1 x 2)	4	24
5025-0505	White	25	76 x 76 x 52 (3 x 3 x 2)	8	48
5026-0909	White	81	133 x 133 x 52 (5.25 x 5.25 x 3.75)	4	24
5026-1010	White	100	133 x 133 x 52 (5.25 x 5.25 x 2.06)		10
5027-0909	White	81	133 x 133 x 95 (5.25 x 5.25 x 3.75)	4	24
374187	White	100	133 x 133 x 52 (5.25 x 5.25 x 2.13)	4	24
341483	White	100	132 x 132 x 52 (5.25 x 5.25 x 3.063)	4	24
330821	White	64	132 x 132 x 52 (5.25 x 5.25 x 2.13)	4	24
378247	White	25	75 x 75 x 51 (2.88 x 2.88 x 2)		24
378220	White	81	132 x 132 x 51 (5.25 x 5.25 x 2)		6
369639	White	81	132 x 132 x 51 (5.25 x 5.25 x 2)		48
369647	White	81	132 x 132 x 75 (5.25 x 5.25 x 2.88)		30
340053	White	100	145 x 145 x 51 (5.75 x 5.75 x 2)		42
340061	White	100	145 x 145 x 75 (5.75 x 5.75 x 2.88)		30

► Thermo Scientific Cryobox Freezer Racks



Durable Nalgene™ stainless steel and Nunc™ aluminum racks conveniently store standard 5.25 x 5.25 in. (132 x 132 mm) cryoboxes.

Freezer racks fit into most common upright and chest freezers.

Cryobox Freezer Racks

Cat No.	Style	Capacity, Compartments	Dimensions, L x W x H, mm (in.)	No. per Pack	No. per Case
DS5037-0004	Vertical	4	14 x 14.3 x 40.6 (5.5 x 5.625 x 16)		1
DS5035-0004	Vertical	7	14 x 14.3 x 40.6 (5.5 x 5.625 x 27.75)		1
DS5035-0009	Vertical	4	8.3 x 8.4 x 22.5 (3.25 x 3.375 x 8.75)		1
5036-0004	Vertical	4	8.3 x 8.4 x 50.2 (3.25 x 3.375 x 19.75)		1
5036-0009	Vertical	9	14 x 14.3 x 22.5 (5.5 x 5.625 x 8.75)	1	4
5038-4322	Vertical	4	14 x 14.3 x 50.2 (5.5 x 5.625 x 19.75)	1	4
5038-4422	Horizontal	12	44.4 x 22.5 x 14.3 (8.875 x 5.625 x 17.5)		2
DS5037-0007	Horizontal	16	59.0 x 22.5 x 14.3 (8.875 x 5.625 x 23.25)		2
367000	Vertical	12	67 x 14.3 x 14 (26.5 x 5.625 x 5.531)		1

► Thermo Scientific Benchtop Coolers



Nunc™ -20°C labtop cooler



Nalgene™ -20°C labtop cooler

Our benchtop coolers protect enzymes, cells, reagents and solutions by maintaining freezer temperatures while on the laboratory bench.

details

- Maintain freezer temperature during the frost-free cycle, power failure and accidental door opening
- Holds 12, 20 or 32 tubes
- Inserts are included for use with 0.2-0.5 mL microcentrifuge tubes
- Printed grid on one-way keyed lid for proper orientation and sample identification
- Molded of impact-resistant polycarbonate with locking handle for long-term use
- Stackable to save space

Benchtop Coolers

Cat. No.	Style	Array	Temp. Rating	Holds Temp, Hours	Dimensions, L x W x H, mm (in.)	No. per Case
355501	non filled/clear	4 x 5	-20°C	<-15°C, 1	226 x 165 x 133 (8.9375 x 6.5 x 8.25)	1
DS5116-0012	non filled/clear	3 x 4	0°C	<1°C, 3.5	151 x 108 x 125 (5.3215 x 4.25 x 4.9375)	1
DS5116-0032	gel-filled/white	4 x 8	0°C	<1°C, 5.0	243 x 157 x 146 (9.5625 x 6.1875 x 5.75)	1
5115-0012	non filled/clear	3 x 4	-20°C	<-15°C, 1	151 x 108 x 125 (5.3125 x 4.25 x 4.9375)	1
5115-0032	gel-filled/white	4 x 8	-20°C	<-15°C, 2	243 x 157 x 146 (9.5625 x 6.1875 x 5.75)	1
5116-1300	Non-filled/clear	3 x 4	0°C	<1°C, 5.0	197 x 140 x 190 (7.75 x 5.5 x 7.5)	1
5116-1600	Non-filled/clear	3 x 4	0°C	<1°C, 5.0	197 x 140 x 190 (7.75 x 5.5 x 7.5)	1

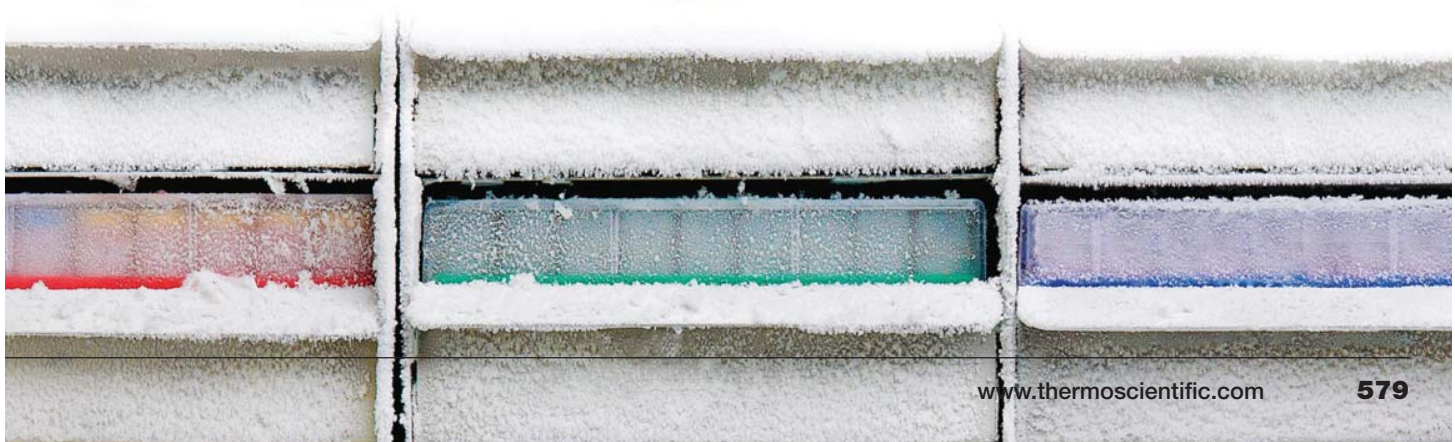

Thermo Scientific Products –
meeting the challenges of science and industry

biological safety cabinets

Leading the way, so you can work in comfort and safety – every day.

For decades, Thermo Scientific biological safety cabinets have been at the forefront of design, performance and safety innovation – enhancing the way you work in the lab. Our family of Class II offerings incorporates technical advances that ensure maximum safety, user comfort and energy savings:

- **Thermo Scientific Herasafe KSP and Maxisafe 2020** – provide superior airflow filtration and easy filter exchange systems ideal for preparing cytotoxic drugs
- **Thermo Scientific Herasafe KS and Safe 2020** – feature an advanced design for easy operation and maximum safety, ideal wherever protection is paramount
- **Thermo Scientific 1300 Series A2 and MSC-Advantage** – combine safety, energy efficiency and value for today's productive laboratory
- **Thermo Scientific 1300 Series B2** – designed and optimized for microbiological work with gases and volatile chemicals



For more product information, go to:
www.thermoscientific.com/bsc

► Thermo Scientific Benchtop Dewars



Benchtop Dewars are used for short-term storage of samples in liquid nitrogen, dry ice-solvent mixtures or ice water.

details

- High-density polyethylene base and cover with polyethylene-coated handle for strong, shatterproof performance
- Double-walled sides and CFC-free foam urethane insulation minimize heat leakage so samples stay cold longer
- Use from -196°C to +100°C
- Pour spout and bottom grip area for easy removal of used liquids
- Vented, insulated cover allows vapor escape but maintains sample temperature

Specifications

Useful Laboratory Cooling Mixtures	Mixture Temperature [†]
Ice Water	0°C (32°F)
Sodium Chloride/Ice (33-g salt/81-g ice)	-21°C (-6°F)
Calcium Chloride/Ice (100-g salt/81-g ice)	-40°C (-40°F)
Chloroform/Liquid Nitrogen (slush)	-64°C (-83°F)
Dry Ice/Acetone	-78°C (-108°F)
Dry Ice/Isopropanol	-78°C (-108°F)
Toluene/Liquid Nitrogen (slush)	-95°C (-139°F)
Pentane/Liquid Nitrogen (slush)	-130°C (-202°F)
Isopentane/Liquid Nitrogen (slush)	-160°C (-256°F)
Liquid Nitrogen	-196°C (-320°F) [‡]

[†] The actual mixture temperature is affected by impurities, and therefore is approximate.

[‡] Caution: At these low temperatures, the flask will withstand thermal shock but becomes brittle. Avoid dropping heavy objects into flask, otherwise use it freely at these temperatures.

Benchtop Dewars

Cat. No.	Capacity, L	Dimensions, Depth x Mouth I.D. x H, mm (in.)	No. per Pack	No. per Case
4150-1000	1	195 x 96 x 251 (7.7 x 3.8 x 9.9)	1	4
4150-2000	2	231 x 122 x 282 (9.1 x 4.8 x 11.1)	1	2
4150-4000	4	295 x 158 x 353 (11.6 x 6.2 x 13.9)	1	2
4150 9000	10	396 x 198 x 470 (15.6 x 7.8 x 18.5)		1

Thermo Scientific Products –
meeting the challenges of science and industry

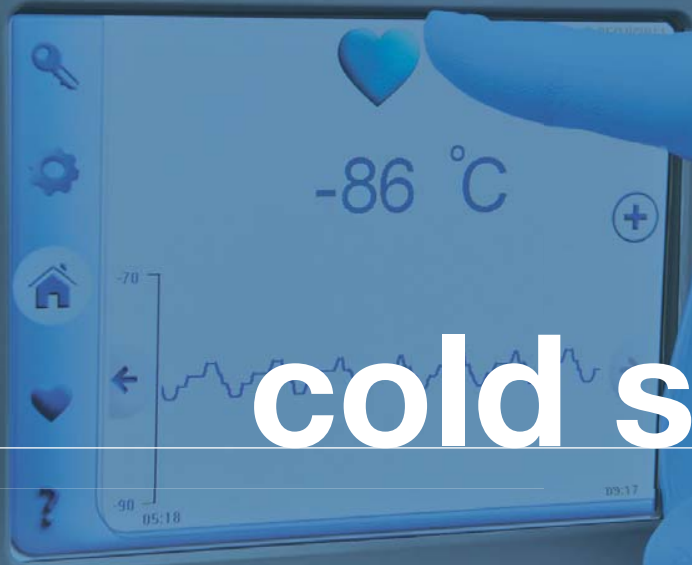

cold storage

We're obsessed with sample integrity.

That's why Thermo Scientific cold storage products offer a complete range of products built for maximum sample protection.

Our ultra-low temperature freezers, lab refrigerators and freezers, and our cryogenic storage solutions deliver everything you expect for worry-free performance, year-after-year:

- Advanced construction, technologies and user interface features for dependable operation and sample security
- Innovative design that maximizes storage capacity per footprint
- Eco-friendly refrigerants and materials to ensure operational responsibility as well as energy efficiency



For more product information, go to:
www.thermoscientific.com/cold

▶ Thermo Scientific Matrix 2D Barcoded ScrewTop Storage Tubes and Caps



Matrix 2D barcoded screwtop tubes



Matrix amber 2D tubes



Thermo Scientific decapper caps and decaps 8 tubes at a time

Matrix™ 2D Barcoded ScrewTop Storage Tubes are optimized for secure sample storage at low temperatures, including vapor phase liquid nitrogen.

Available in 0.5 mL through 12 mL volume capacity, these tubes are molded from medical grade resins and the proprietary barcoding process produces a permanent, high contrast 2D barcode, offering maximum reliability and traceability of valuable samples. Used in combination with VisionMate 2D barcode readers, manual and automated capping equipment, and labelling options, the 2D ScrewTop Tubes meet a range of manual and automated long-term storage needs.

Proprietary barcoding process applies a permanent 2D barcode on the Thermo Scientific storage tracking products allowing secure tracking and storage of valuable samples, ranging in volumes from 0.5 mL through 12 mL. Complemented by a comprehensive range of manual or integrated capping/decapping equipment, VisionMate linear and 2D barcode readers and labelling accessories, the ScrewTop tubes and accessories can meet your storage needs for a range of applications.

details

Secure Tracking

- Solid one piece construction eliminates the risk of labels falling off during storage, even when used at cryogenic temperatures
- Permanently attached, laser-etched 2D barcode on the bottom of each tube allows you to scan and decode tubes at once without removing them from the rack, and allows data to be associated with each tube
- A range of VisionMate readers accommodates single tube to full rack reading to meet various throughput requirements. Further maximizing flexibility, barcode data can be easily inputted into a range of database or application formats
- VisionMate reader software includes built in error correction to avoid barcode misreads
- ScrewTop tubes are autoclavable with caps loosened
- Tube material: Virgin class VI medical grade polypropylene
- Racks are constructed of Acrylonitrile butadiene styrene (ABS)
- Cap material: Virgin class VI medical grade polypropylene with virgin class VI medical grade silicone O-ring
- ScrewTop Tubes are compatible with storage at a wide temperature range of -180° through +121°C

Superior Storage Format

- Supplied in an standard microplate format latch racks, storage space can be maximized and tubes can be easily used with existing multichannel manual pipettes or automated liquid handling equipment
- Latch Rack design allows samples to be stored securely and enables one-hand operation during pipetting applications
- Several capping/ decapping options are available to meet various throughput levels and manual or automated procedures. Available options include single tube, 8- tube, or 96 simultaneous cap application and removal
- 12 mL tube allows microplate format storage of large volumes, including clinical samples, powders, tissue, and plant materials, while still compatible with the range of accessory equipment

► Thermo Scientific Matrix 2D Barcoded ScrewTop Storage Tubes and Caps continued

details

Stringent Quality Control

- Every 2D barcode is scanned for readability and checked against a full database of all previous 2D barcodes to ensure there are zero duplicates across the entire Thermo Scientific Matrix storage tube product line
- Each tube is leak tested to ensure tube integrity and the security of your samples
- 100% quality control checks that every code is unique and readable
- All tubes and trays are supplied free from DNA, RNase, DNase, and endotoxins

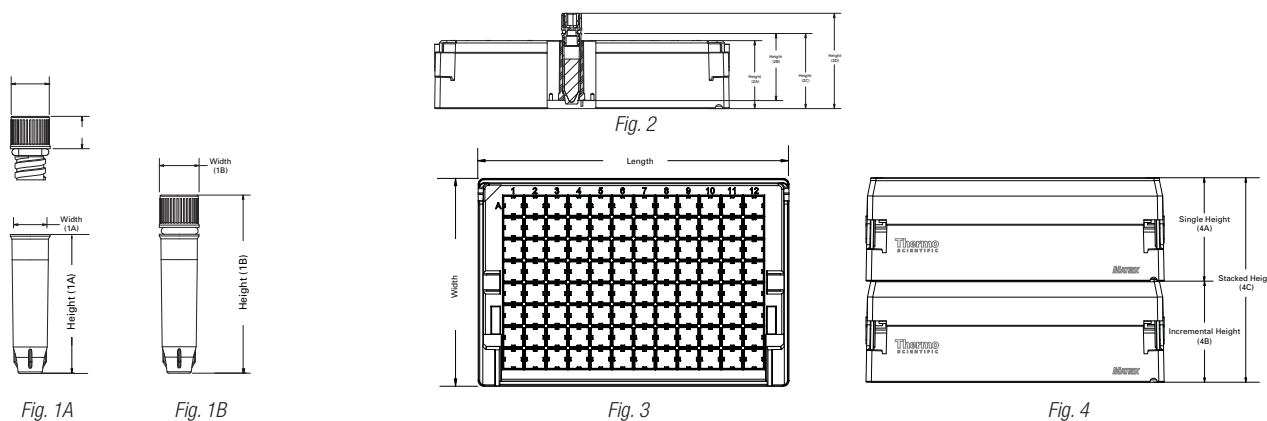

Fig. 1A

Fig. 1B

Fig. 2

Fig. 3

Fig. 4

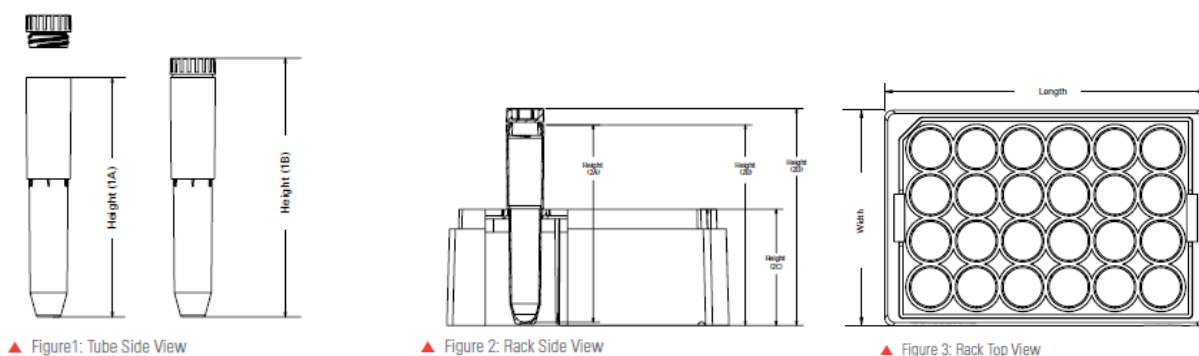

▲ Figure 1: Tube Side View

▲ Figure 2: Rack Side View

▲ Figure 3: Rack Top View

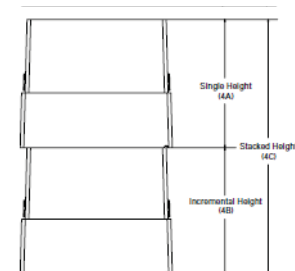

▲ Figure 4: Stacked Rack View

Matrix 2D Barcoded ScrewTop Tubes and Caps

Description		0.5 mL ScrewTop Storage Tubes	1.0 mL ScrewTop Storage Tubes	12.0 mL ScrewTop Storage Tubes
Item No.		3743, 3744, 3745	3740, 3741, 3742	3775, 3778
Figure 1A: Tube Side View	Width (1A)	7.40±0.10 [0.290±0.002]	7.40±0.10 [0.290±0.002]	–
	Height (1A)	30.60±0.20 [1.204±0.007]	44.00±0.10 [1.732±0.003]	95.25±0.08 [3.750±0.003]
Figure 1B: Tube Side View w/ ScrewTop	Width (1B)	8.70±0.10 [0.344±0.003]	8.70±0.10 [0.344±0.003]	–
	Height (1B)	39.20 [1.543]	52.60 [2.071]	102.97±0.20 [4.054±0.008]
Figure 2: Rack Side View	Height (2A)	29.50±0.10 [1.160±0.005]	38.10±0.10 [1.500±0.005]	94.50±0.20 [3.720±0.008]
	Height (2B)	29.10±0.10 [1.145±0.005]	42.50±0.20 [1.673±0.008]	96.00±0.20 [3.780±0.008]
	Height (2C)	32.60±0.30 [1.282±0.012]	46.00±0.20 [1.809±0.008]	55.60±0.13 [2.190±0.005]
	Height (2D)	41.30±0.40 [1.626±0.017]	54.60±0.30 [2.149±0.110]	103.73±0.33 [4.084±0.130]
Figure 3: Rack Top View	Length	127.75±0.13 [5.029±0.005]	127.75±0.13 [5.029±0.005]	127.76±0.13 [5.030±0.005]
	Width	85.46±0.13 [3.364±0.005]	85.46±0.13 [9.964±0.005]	85.47±0.13 [3.365±0.005]
Figure 4: Stacked Rack View	Single Height (4A)	44.32±0.25 [1.745±0.010]	58.42±0.25 [2.300±0.010]	107.82±0.25 [4.245±0.010]
	Incremental Height (4B)	43.31±0.25 [1.705±0.010]	57.30±0.25 [2.220±0.010]	106.30±0.25 [4.185±0.010]
	Stacked Height (4C)	87.63±0.51 [3.450±0.020]	114.81±0.51 [4.520±0.020]	214.12±0.51 [8.430±0.020]



► Thermo Scientific Matrix 2D Barcoded ScrewTop Storage Tubes and Caps continued

Matrix 2D Barcoded ScrewTop Tubes and Caps

Cat. No.	Description	Cap Color	Size, mL	Sterile	Bulk	No. per Case
500 µL V-Bottom ScrewTop Tubes, Bulk, 480/Cs. 480 tubes/ Case						
3743MTX	Clear ScrewTop Tube	Clear	0.5	X	X	480 tubes/ Case
3743BLU-MTX	Clear ScrewTop Tube	Blue	0.5	X	X	480 tubes/ Case
3743GRE-MTX	Clear ScrewTop Tube	Green	0.5	X	X	480 tubes/ Case
3743PUR-MTX	Clear ScrewTop Tube	Purple	0.5	X	X	480 tubes/ Case
3743RED-MTX	Clear ScrewTop Tube	Red	0.5	X	X	480 tubes/ Case
3743WHI-MTX	Clear ScrewTop Tube	White	0.5	X	X	480 tubes/ Case
3743YEL-MTX	Clear ScrewTop Tube	Yellow	0.5	X	X	480 tubes/ Case
500 µL V-Bottom ScrewTop Tubes, 5 Racks of 96/Cs.						
3744MTX	Clear ScrewTop Tube	Clear	0.5	X		5 Latch Racks of 96/ Case
3744BLU-MTX	Clear ScrewTop Tube	Blue	0.5	X		5 Latch Racks of 96/ Case
3744GRE-MTX	Clear ScrewTop Tube	Green	0.5	X		5 Latch Racks of 96/ Case
3744PUR-MTX	Clear ScrewTop Tube	Purple	0.5	X		5 Latch Racks of 96/ Case
3744RED-MTX	Clear ScrewTop Tube	Red	0.5	X		5 Latch Racks of 96/ Case
3744WHI-MTX	Clear ScrewTop Tube	White	0.5	X		5 Latch Racks of 96/ Case
3744YEL-MTX	Clear ScrewTop Tube	Yellow	0.5	X		5 Latch Racks of 96/ Case
3743AMB	Amber ScrewTop Tube	Red	0.5	X		5 Latch Racks of 96/ Case
3745MTX	Clear ScrewTop Tube	no cap	0.5	X		5 Latch Racks of 96/ Case
3744AMB	Amber ScrewTop Tube	no cap	0.5	X		5 Latch Racks of 96/ Case
1.0 mL V-Bottom ScrewTop Tubes, Bulk, 480/Cs.						
3740MTX	Clear ScrewTop Tube	Clear	1.0	X	X	480 tubes/ Case
3740BLU-MTX	Clear ScrewTop Tube	Blue	1.0	X	X	480 tubes/ Case
3740GRE-MTX	Clear ScrewTop Tube	Green	1.0	X	X	480 tubes/ Case
3740PUR-MTX	Clear ScrewTop Tube	Purple	1.0	X	X	480 tubes/ Case
3740RED-MTX	Clear ScrewTop Tube	Red	1.0	X	X	480 tubes/ Case
3740WHI-MTX	Clear ScrewTop Tube	White	1.0	X	X	480 tubes/ Case
3740YEL-MTX	Clear ScrewTop Tube	Yellow	1.0	X	X	480 tubes/ Case
1.0 mL V-Bottom ScrewTop Tubes, 5 Racks of 96/Cs.						
3741MTX	Clear ScrewTop Tube	Clear	1.0	X		5 Latch Racks of 96/ Case
3741BLU-MTX	Clear ScrewTop Tube	Blue	1.0	X		5 Latch Racks of 96/ Case
3741GRE-MTX	Clear ScrewTop Tube	Green	1.0	X		5 Latch Racks of 96/ Case
3741PUR-MTX	Clear ScrewTop Tube	Purple	1.0	X		5 Latch Racks of 96/ Case
3741RED-MTX	Clear ScrewTop Tube	Red	1.0	X		5 Latch Racks of 96/ Case
3741WHI-MTX	Clear ScrewTop Tube	White	1.0	X		5 Latch Racks of 96/ Case
3741YEL-MTX	Clear ScrewTop Tube	Yellow	1.0	X		5 Latch Racks of 96/ Case
3741AMB	Amber ScrewTop Tube	Red	1.0	X		5 Latch Racks of 96/ Case
3742MTX	Clear ScrewTop Tube	no cap	1.0	X		5 Latch Racks of 96/ Case
3742AMB	Amber ScrewTop Tube	no cap	1.0	X		5 Latch Racks of 96/ Case
12.0 mL V-Bottom ScrewTop Tubes						
3770	Clear ScrewTop Tube	Clear	12.0	X	X	100 Tubes/Case
3775	Clear ScrewTop Tube	Clear	12.0	X		4 Latch Racks of 24/Case
3778	Clear ScrewTop Tube	no cap	12.0	X		4 Latch Racks of 24/Case

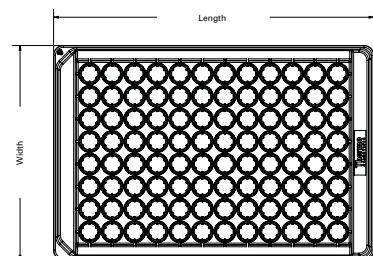

Fig. 1

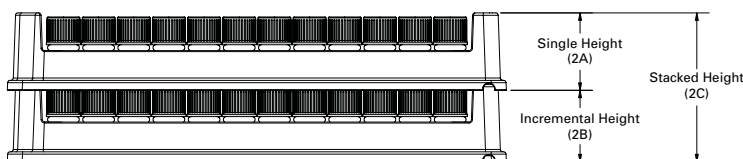

Fig. 2

Matrix 2D Barcoded ScrewTop Cap Tray

Description	ScrewTop Cap Tray	
Item No.	4906, 4477 (All Colors)	
Figure 1: Tray Top View	Length	127.75±0.25 [5.03±0.010]
	Width	85.580.25± [3.37±0.010]
Figure 2: Stacked Tray View	Single Height (2A)	19.81±0.13 [0.78±0.005]
	Incremental Height (2B)	18.29±0.25 [0.72±0.010]
	Stacked Height (2C)	38.10±0.25 [1.50±0.010]

Caps for 500 µL and 1.0 mL ScrewTop Tubes

Cat. No.	Cap Color	Compatible with Tube Volumes	No. per Case
4470MTX	Colorless	0.5 mL; 1.0 mL	500
4470BLUE-MTX	Blue	0.5 mL; 1.0 mL	500
4470GRE-MTX	Green	0.5 mL; 1.0 mL	500
4470PUR-MTX	Purple	0.5 mL; 1.0 mL	500
4470RED-MTX	Red	0.5 mL; 1.0 mL	500
4470WHI-MTX	White	0.5 mL; 1.0 mL	500
4470YEL-MTX	Yellow	0.5 mL; 1.0 mL	500

Caps for 12 mL ScrewTop Tubes, 100/Cs.

4440MTX	Solid	12.0 mL	100
---------	-------	---------	-----

ScrewTop Tube Cap Tray

4477-MTX	Colorless	0.5 mL; 1.0 mL	5 cap trays of 96
4477BLU-MTX	Blue	0.5 mL; 1.0 mL	5 cap trays of 96
4477GRE-MTX	Green	0.5 mL; 1.0 mL	5 cap trays of 96
4477PUR-MTX	Purple	0.5 mL; 1.0 mL	5 cap trays of 96
4477RED-MTX	Red	0.5 mL; 1.0 mL	5 cap trays of 96
4477WHI-MTX	White	0.5 mL; 1.0 mL	5 cap trays of 96
4477YEL-MTX	Yellow	0.5 mL; 1.0 mL	5 cap trays of 96
4906-MTX	without caps, tray only	0.5 mL; 1.0 mL	5 cap trays

Color Inserts for 500 µL and 1.0 mL ScrewTop Tube Caps

4471MTX	Red	0.5 mL; 1.0 mL	500 inserts
4472MTX	Yellow	0.5 mL; 1.0 mL	500 inserts
4473MTX	Blue	0.5 mL; 1.0 mL	500 inserts
4474MTX	Green	0.5 mL; 1.0 mL	500 inserts
4475MTX	White	0.5 mL; 1.0 mL	500 inserts
4476MTX	Purple	0.5 mL; 1.0 mL	500 inserts

► Thermo Scientific Nunc Cryobank Tube Systems

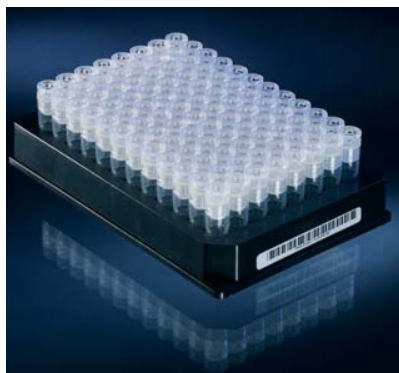

Nunc Cryobank 1.0 mL tubes



Nunc Cryobank tubes in universal rack for easy tube handling



Cryobank tubes in use

Nunc™ Cryobank storage tubes take traditional cryostorage to the next level with laser etched 2D barcodes and standard microplate format racks, offering greater storage capability compared to standard cryoboxes.

Compatible with the complete line of 2D barcode readers, capping/ decapping equipment and labelling options, Cryobank tubes can be used in manual or automated storage of diagnostic and biological samples down to vapor phase liquid nitrogen. Cryobank products are available in a volume range of 0.5 mL through 5.0 mL, and complemented by a range of certifications.

details

Nunc Cryobank tubes take traditional cryostorage to the next level with higher density storage format and reliable 2D barcode traceability. Compatible with the complete line of 2D barcode readers, capping/ decapping equipment, and labelling options, Cryobank products are a perfect match for biological, genomic, and diagnostic sample storage.

Secure Tracking

- Permanently attached, laser etched 2D barcode on the bottom of the tube allows you to scan and decode the entire rack at once without removing them from the rack, and allows data to be associated with each tube
- Solid one piece construction eliminates the risk of labels falling off during cryogenic storage, preserving the identity of valuable sample material
- Utilize a range of 2D reading products to decode individual tubes or complete microplate footprint racks. Readers allow flexible output to store data in multiple database formats

Superior Storage Format

- Cryobank tubes are available in space conscious microplate format racks or can be stored in traditional cryoboxes, accommodating your preferred storage format
- Microplate format is compatible with your existing multichannel manual pipettes and automated liquid handling equipment
- Unique anti-rotation feature allows compatibility with automated decapping/ capping equipment in single, 8-channel, or full-rack options to accommodate multiple throughput requirements.
- TPE gasketed polypropylene cap provides superior seal during high or low temperature storage
- Low-binding surface allows maximum recovery of low concentration samples

Certified to meet your storage needs

- CE certified and conforms to IATA requirements for diagnostic use and transportation
- Certified DNase, RNase, pyrogene and toxin free
- Sterility assurance level 10^{-6} for the most sensitive sample storage

Stringent Quality Control

- 2D barcodes are scanned for readability and checked against a full database of previous barcodes to ensure no duplicates across the Cryobank storage tube product line.
- Leak testing validation performed during the manufacturing process to ensure sample integrity is maintained

Nunc Cryobank and Bank-It Tube Systems

Cat No	Description	Capped	Size, mL	Bottom	Sterile	Racked	Bulk	No. per Case
374025	Clear Cryobank Tube, Blue Cap	X	0.5	flat	X	X		10 racks of 96 tubes/case
374026	Clear Cryobank Tube, Red Cap	X	0.5	flat	X	X		10 racks of 96 tubes/case
374027	Clear Cryobank Tube, Green Cap	X	0.5	flat	X	X		10 racks of 96 tubes/case
374080	Clear Cryobank Tube, Clear Cap	X	0.5	flat	X		X	10 bags of 96 tubes/case
374082	Clear Cryobank Tube, Clear Cap	X	0.5	flat	X	X		2 racks of 96 tubes/case
374086	Clear Cryobank Tube, Clear Cap	X	0.5	flat	X	X		10 racks of 96 tubes/case
374074	Clear Bank-It Tube, Clear Cap	X	0.5	flat	X	X		10 racks of 96 tubes/case
374075	Clear Bank-It Tube, Clear Cap	X	0.5	flat	X	X		10 racks of 96 tubes/case
374083	Clear Cryobank Tube, Clear Cap, Uncoded	X	0.5	flat	X	X		2 racks of 96 tubes/case
374087	Clear Cryobank Tube, Clear Cap, Uncoded	X	0.5	flat	X	X		10 racks of 96 tubes/case
374099	Clear Cryobank Tube, Red Cap, Uncoded	X	0.5	flat	X	X		10 racks of 96 tubes/case
374100	Clear Cryobank Tube, Blue Cap, Uncoded	X	0.5	flat	X	X		10 racks of 96 tubes/case
374081	Clear Cryobank Tube, Clear Cap	X	1.0	flat	X		X	10 bags of 96 tubes/case
374084	Clear Cryobank Tube, Clear Cap	X	1.0	flat	X	X		2 racks of 96 tubes/case
374088	Clear Cryobank Tube, Clear Cap	X	1.0	flat	X	X		10 racks of 96 tubes/case
374110	Clear Cryobank Tube, Green Cap	X	1.0	flat	X	X		10 racks of 96 tubes/case
374120	Clear Cryobank Tube, Red Cap	X	1.0	flat	X	X		10 racks of 96 tubes/case
374130	Clear Cryobank Tube, Blue Cap	X	1.0	flat	X	X		10 racks of 96 tubes/case
374079	Clear Bank-It Tube, Clear Cap	X	1.0	flat	X	X		10 racks of 96 tubes/case
374085	Clear Cryobank Tube, Clear Cap, Uncoded	X	1.0	flat	X	X		2 racks of 96 tubes/case
374089	Clear Cryobank Tube, Clear Cap, Uncoded	X	1.0	flat	X	X		10 racks of 96 tubes/case
374094	Clear Cryobank Tube, Clear Cap, Alphacode	X	1.0	flat	X	X		10 racks of 96 tubes/case
374131	Clear Cryobank Tube, Gray Cap	X	2.0	flat	X		X	20 bags of 48 tubes/case
374132	Clear Cryobank Tube, Yellow Cap	X	2.0	flat	X		X	20 bags of 48 tubes/case
374133	Clear Cryobank Tube, Blue Cap	X	2.0	flat	X		X	20 bags of 48 tubes/case
374134	Clear Cryobank Tube, Green Cap	X	2.0	flat	X		X	20 bags of 48 tubes/case
374135	Clear Cryobank Tube, Red Cap	X	2.0	flat	X		X	20 bags of 48 tubes/case
374221	Clear Cryobank Tube, Clear Cap	X	2.0	flat	X	X		10 racks of 48 tubes/case
374258	Clear Cryobank Tube, Clear Cap	X	2.0	flat	X		X	20 bags of 48 tubes/case
374259	Clear Cryobank Tube, Clear Cap, Uncoded	X	2.0	flat	X		X	20 bags of 48 tubes/case
374223	Clear Cryobank Tube, Clear Cap, Uncoded	X	2.0	flat	X	X		10 racks of 48 tubes/case
374223	Clear Cryobank Tube, Clear Cap, Uncoded	X	2.0	flat	X	X		10 racks of 48 tubes/case
374220	Clear Cryobank Tube, Clear Cap	X	5.0	flat	X	X		10 racks of 48 tubes/case
374260	Clear Cryobank Tube, Clear Cap, Uncoded	X	5.0	flat	X		X	11 bags of 48 tubes/case
374261	Clear Cryobank Tube, Clear Cap	X	5.0	flat	X		X	11 bags of 48 tubes/case
374222	Clear Cryobank Tube, Clear Cap, Uncoded	X	5.0	flat	X	X		10 racks of 48 tubes/case
374222	Clear Cryobank Tube, Clear Cap, Uncoded	X	5.0	flat	X	X		10 racks of 48 tubes/case

► Thermo Scientific Nunc Cryobank and Vial Systems continued

Nunc Cryobank and Bank-It Tube Accessories

Cat. No.	Description	Color	Sterile	Packaging
374017	Nunc Cryobank Caps for 0.5 mL and 1.0 mL Cryobank and Bank-it Tubes, Natural, 10 racks of 96/case, Irradiated	Natural	Yes-Irradiated	10 racks of 96/case, Irradiated
374018	Nunc Cryobank Caps for 0.5 mL and 1.0 mL Cryobank and Bank-it Tubes, Green, 10 racks or 96/case	Green	No	10 racks of 96/case, Irradiated
374019	Nunc Cryobank Caps for 0.5 mL and 1.0 mL Cryobank and Bank-it Tubes, Red, 10 racks or 96/case	Red	No	10 racks of 96/case, Irradiated
374021	Nunc Cryobank Caps for 0.5 mL and 1.0 mL Cryobank and Bank-it Tubes, Blue, 10 racks or 96/case	Blue	No	10 racks of 96/case, Irradiated
367014	Nunc Cryobank and Bank-it 74 cm rack accommodates (19) 0.5 mL Cryobank or Bank-it Racks or (13) 1.0 mL Cryobank or Bank-it Racks, 1 each			1 each
374009	Nunc Cryobank and Bank-it Rack, Tube Press out Tool, 1 Each			1 each

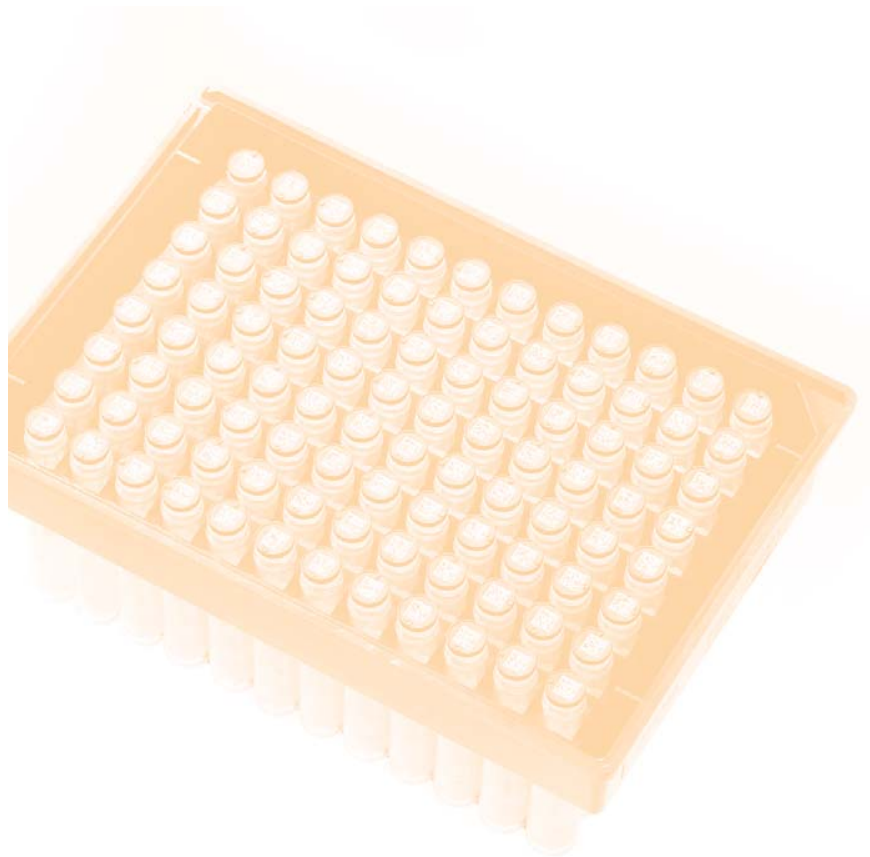

▶ Thermo Scientific Matrix 2D Barcoded Storage Tubes



Wide variety of volumes and formats



Glass tubes with 2D barcode

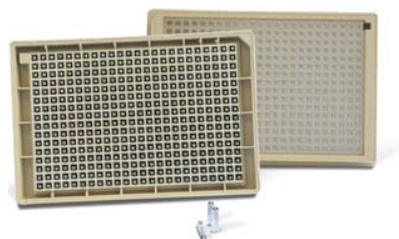

Low-volume 384-format



Low-volume tubes with 2D barcode

Matrix 2D Barcoded Storage Tubes allow robust storage and tracking of sample volumes ranging from 0.1 mL to 1.4 mL in 96- and 384- format.

Tubes are molded from medical grade resins and the proprietary barcoding process produces a permanent, high contrast 2D barcode, offering maximum reliability and traceability of compound, biological, and genomic samples. Available with a range of sealing options and used with Thermo Scientific VisionMate* barcode readers, the Matrix 2D barcoded storage tubes can improve a range of sample management needs and workflows.

details

Secure Tracking

- A permanently-bonded, unique 2D barcode is laser-etched onto the base of every Matrix 2D barcoded storage tube to enable secure sample identification and tracking
- A range of VisionMate 2D barcode readers is available to meet your application and throughput needs
- VisionMate systems are flexible enough to allow 2D barcode data to be integrated into various applications, databases, and automated systems
- Once sample data is stored, just scan the tube using the database Find feature to instantly access sample information and identify the contents of each storage tube

Superior Storage Rack Design

- Unlike traditional storage tubes or blocks, Matrix 96-format 2D barcoded storage tubes are available in proprietary, stackable, microplate footprint Latch Racks to save precious space in your freezer, refrigerator, compound store or on the bench top
- The latch rack design enables manual multichannel pipette access to 2D tubes and eliminates contamination risk with lid design that does not contact the benchtop
- The latch rack lid can be lifted robotically for 2D tube access with automated equipment and high-throughput applications

Stringent Quality Control

- Every 2D barcoded storage tube is scanned to guarantee readability and each code is checked against a full database of all previously assigned 2D codes to ensure zero duplicates across the entire line of Matrix 2D barcoded storage tubes
- Every storage tube is leak tested to ensure the integrity and security of samples

Storage Tracking Solutions for Any Laboratory

- Available with a range of sealing options including solid and pre-slit Duraseals™ and Sepraseals to meet your individual storage requirements
- Glass tubes can be used for storing samples in DMSO, chlorinated solvents and other harsh chemicals and applications where newly synthesized compounds that need to be dried down or lyophilized
- Custom 2D coding options are available to meet your laboratory's individual database or tracking requirements
- 2D storage tubes are compatible with Thermo Scientific freezer racks that allow optimal utilization of storage space

Recommended for: Individual sample retrieval; instant sample identification; secure identification of archived samples; secure shipping of samples; storage of genomic samples, DMSO dissolved compounds or any other samples; and tracking of samples during manufacturing storage of biological material.

► Thermo Scientific Matrix 2D Barcoded Storage Tubes

0.5 - 1.4 mL Tubes



Fig. 1: Tube Side View

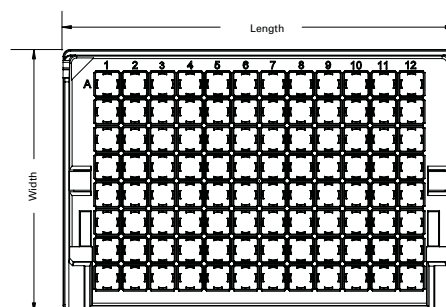

Fig. 3: Rack Top View

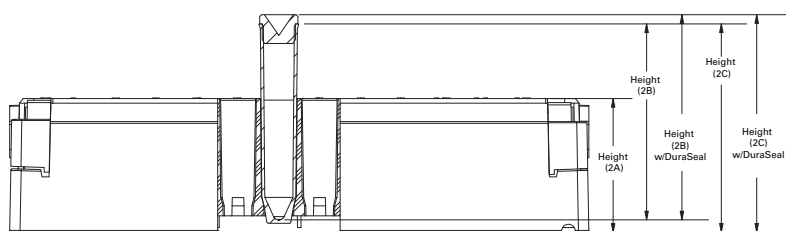

Fig. 2: Rack Side View

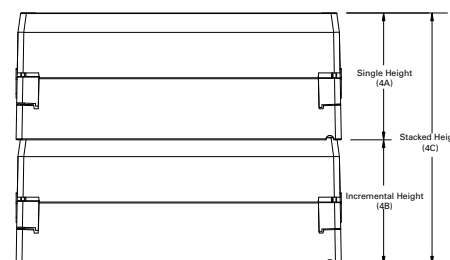

Fig. 4: Stacked Rack View

Matrix* 2D Barcoded Storage Tubes

Description		0.1 mL Storage Tubes	0.5 mL Storage Tubes	0.5 mL Storage Tubes with Duraseal Installed	1.4 mL Storage Tubes	1.4 mL Storage Tubes with Duraseal Installed	1.4 mL Storage Tubes with Human Readable Code
Cat No.		3815	3734, 3735, 4898	3736, 3737, 4899	3791, 3792, 4890	3801, 4890	3711, 3112, 4890
Figure 1: Tube Side View	Width (1A)	4.2 mm [0.17]	8.74 ± 0.08 [0.344 ± 0.003]	8.74±0.08 [0.344±0.003]	8.74±0.08 [0.344±0.003]	8.74±0.08 [0.344±0.003]	8.74±0.08 [0.344±0.003]
	Width (1B)	–	6.83±0.05 [0.269±0.002]	8.43±0.13 [0.332±0.005]	6.83±0.05 [0.269±0.002]	8.43±0.13 [0.332±0.005]	6.83±0.05 [0.269±0.002]
	Height	15 mm [0.5901]	21.38±0.08 [0.842±0.003]	23.39±0.20 [0.921±0.008]	43.99±0.08 [1.732±0.003]	46.01±0.20 [1.811±0.008]	43.99±0.08 [1.732±0.003]
Figure 2: Rack Side View	Height (2A)	18.6 mm [0.732]	14.22±0.13 [0.560±0.005]	14.22±0.13 [0.560±0.005]	29.46±0.13 [1.160±0.005]	29.46±0.13 [1.160±0.005]	29.46±0.13 [1.160±0.005]
	Height (2B)	14 mm [0.551]	20.929±0.08 [0.824±0.003]	20.929±0.08 [0.824±0.003]	43.231±0.08 [1.702±0.003]	43.231±0.08 [1.702±0.003]	43.332±0.20 [1.710±0.010]
	Height (2C)	16.5 mm [0.469]	22.07±0.20 [0.869 ±0.008]	24.08±0.33 [0.948±0.013]	45.95±0.20 [1.809±0.008]	47.96±0.01 [1.888±0.001]	45.949±0.20 [1.810±0.010]
Figure 3: Rack Top View	Length	127.76 mm [5.03]	127.76±0.13 [5.030±0.005]	127.76±0.13 [5.030±0.005]	127.76±0.13 [5.030±0.005]	127.76±0.13 [5.030±0.005]	127.76±0.13 [5.030±0.005]
	Width	85.47 mm [3.364]	85.47±0.13 [3.365±0.005]	85.47±0.13 [3.365±0.005]	85.47±0.13 [3.365±0.005]	85.47±0.13 [3.365±0.005]	85.47±0.13 [3.365±0.005]
Figure 4: Stacked Rack View	Single Height (4A)	18.6 mm [0.771]	25.96±0.25 [1.022±0.010]	27.48±0.25 [1.082±0.010]	49.84±0.25 [1.962±0.010]	49.84±0.25 [1.962±0.010]	49.84±0.25 [1.962±0.010]
	Incremental Height (4B)	18.6 mm [0.771]	22.61±0.10 [0.890±0.250]	26.42±0.25 [1.040±0.010]	48.82±0.25 [1.922±0.010]	48.82±0.25 [1.922±0.010]	48.82±0.25 [1.922±0.010]
	Stacked Height (4C)	37.2 mm [1.464]	48.56±0.51 [1.912±0.020]	53.90±0.51 [2.122±0.020]	98.65±0.51 [3.884±0.020]	98.65±0.51 [3.884±0.020]	98.65±0.51 [3.884±0.020]

Matrix 2D Barcoded Storage Tubes

Cat No	Description	Size, mL	Format	Sterile	Duraseal Installed	Racked	Bulk	No. Per Case
3710MTX	Matrix, 2D barcoded w/ human readable code	1.4	96				X	1000 tubes/ Case
3711MTX	Matrix, 2D barcoded w/ human readable code	1.4	96			X		10 Latch Racks of 96 tubes/case
3712MTX	Matrix, 2D barcoded w/ human readable code	1.4	96	X		X		10 Latch Racks of 96 tubes/case
3713MTX	Matrix, 2D barcoded w/ human readable code	1.4	96			X		10 Latch Racks of 96 tubes/case
3714MTX	Matrix, 2D barcoded w/ human readable code	1.4	96	X		X		10 Latch Racks of 96 tubes/case
3729MTX	Matrix, 2D barcoded	0.75	96		X	X		10 Latch Racks of 96 tubes/case
3730MTX	Matrix, 2D barcoded	0.75	96				X	1000 tubes/ Case
3731MTX	Matrix, 2D barcoded	0.75	96			X		10 Latch Racks of 96 tubes/case
3732MTX	Matrix, 2D barcoded	0.75	96	X		X		10 Latch Racks of 96 tubes/case
3734MTX	Matrix, 2D barcoded	0.5	96			X		10 Latch Racks of 96 tubes/case
3735MTX	Matrix, 2D barcoded	0.5	96	X		X		10 Latch Racks of 96 tubes/case
3736MTX	Matrix, 2D barcoded	0.5	96		X	X		10 Latch Racks of 96 tubes/case
3737MTX	Matrix, 2D barcoded	0.5	96	X	X	X		10 Latch Racks of 96 tubes/case
3750MTX	Matrix, 2D barcoded	0.5	96				X	960 tubes /Case
3790MTX	Matrix, 2D barcoded	1.4	96				X	1000 tubes /Case
3791MTX	Matrix, 2D barcoded	1.4	96			X		10 Latch Racks of 96 tubes/case
3792MTX	Matrix, 2D barcoded	1.4	96	X		X		10 Latch Racks of 96 tubes/case
3794MTX	Matrix, 2D barcoded	1.4	96			X		10 Latch Racks of 96 tubes/case
3801MTX	Matrix, 2D barcoded	1.4	96		X	X		10 Latch Racks of 96 tubes/case
3850MTX	Matrix, 2D barcoded, glass	1.0	96			X		5 Latch Racks of 96 tubes/case
3815MTX	Matrix, 2D barcoded	0.1	384			X		20 racks of 384 tubes/case

Empty Racks for Matrix 2D Barcoded Storage Tubes

Cat No	Description	Packaging
4890MTX	Matrix Empty Latch Rack for 1.4 mL tubes	10 racks/cs
4893MTX	Matrix Empty Snap Rack for 1.4 mL tubes	10 racks/cs
4896MTX	Matrix Empty Latch Racks for 0.75 mL tubes	10 racks/cs
4898MTX	Matrix Empty Latch Racks for 500 µL tubes	10 racks/cs
4899MTX	Matrix Empty Latch Racks for 500 µL tubes w/ DuraSeals*	10 racks/cs
4901MTX	Matrix Empty Latch Rack fixture lid for 0.75 mL Matrix tubes, white	10/cs

► Thermo Scientific Matrix Blank and Alphanumeric Storage Tubes



Matrix™ Blank and Alphanumeric storage tubes allow robust, secure, high-density storage of valuable samples.

Samples can be identified using the alphanumeric code on the bottom of each tube. Compatible with the automation-friendly full line of seals and capping equipment, and provided in manual and automation friendly rack formats, these tubes are ideal for scaling up from microplate or deep well block sample storage or storing individual samples that do not require 2D tracking.

details

Highest Quality

- Matrix storage tubes are manufactured from medical grade virgin polypropylene
- Tubes are 100% leak tested to ensure sample integrity and security
- Tubes are validated to be free of DNase, RNase, and endotoxins

Superior Storage Rack Design

- Unlike traditional storage tubes or blocks, Matrix blank and alphanumeric storage tubes are available in our specially-designed, stackable, microplate-footprint latch racks of 96 tubes for individual sample, access and removal
- The latch rack design enables multichannel pipette access and eliminates contamination risk with a lid that never touches the bench top when open
- The latch rack design is also compatible with automated equipment, as the lid can be lifted robotically for high-throughput applications

Clear Designations

- Matrix alphanumeric storage tubes are clearly marked with high contrast printing on the base of each tube, designating their appropriate well location within a rack, for easy identification
- Enhance ease of visual identification with colored SeptraSeal capping options

Capping Options

- Several sealing options are available, including the Matrix line of CapMats and CapStrips for sealing multiple tubes and the Matrix SeptraSeal capping systems for individual tube sealing, access and piercing
- Applied with the SuperSealer, sealing is secure and consistent every time

Recommended for: Individual sample retrieval; shipping samples; storing DNA, compounds, or any other samples.

Compatible Products: Capping systems, SeptraSeals, SuperSealer.

Matrix™ Blank and Alphanumeric Storage Tubes

Description		0.75 mL Storage Tubes	1.4 mL Storage Tubes
Cat. No.		4271, 4272, 4273, 4274, 4896	4247, 4248, 4249, 4250, 4251, 4252, 4253, 4254, 4890
Figure 1: Tube Side View	Width (1A)	8.74 ± 0.08 [0.344 ± 0.003]	8.74 ± 0.08 [0.344 ± 0.003]
	Width (1B)	6.83 ± 0.03 [0.269 ± 0.001]	6.83 ± 0.05 [0.269 ± 0.002]
	Height	33.60 ± 0.13 [1.323 ± 0.005]	43.99 ± 0.08 [1.732 ± 0.003]
Figure 2: Rack Side View	Height (2A)	29.46 ± 0.13 [1.160 ± 0.005]	29.46 ± 0.13 [1.160 ± 0.005]
	Height (2B)	32.92 ± 0.08 [1.296 ± 0.003]	43.33 ± 0.08 [1.706 ± 0.003]
	Height (2C)	35.56 ± 0.25 [1.400 ± 0.010]	45.95 ± 0.20 [1.809 ± 0.008]
Figure 3: Rack Top View	Length	127.76 ± 0.13 [5.030 ± 0.005]	127.76 ± 0.13 [5.030 ± 0.005]
	Width	85.47 ± 0.13 [3.365 ± 0.005]	85.47 ± 0.13 [3.365 ± 0.005]
Figure 4: Stacked Rack View	Single Height (4A)	39.37 ± 0.25 [1.550 ± 0.100]	49.84 ± 0.25 [1.962 ± 0.100]
	Incremental Height (4B)	38.36 ± 0.25 [1.510 ± 0.100]	48.82 ± 0.25 [1.922 ± 0.100]
	Stacked Height (4C)	98.65 ± 0.51 [3.884 ± 0.200]	98.65 ± 0.51 [3.884 ± 0.200]

Matrix Blank and Alphanumeric Storage Tubes

Cat No	Capacity, mL	Label	Sterile	Packaging
4170MTX	0.75	Blank	No	Bulk, 1000/case
4271MTX	0.75	Blank	No	10 Latch Racks of 96 tubes/case
4272MTX	0.75	Blank	Yes	10 Latch Racks of 96 tubes/case
4273MTX	0.75	Alphanumeric	No	10 Latch Racks of 96 tubes/case
4274MTX	0.75	Alphanumeric	Yes	10 Latch Racks of 96 tubes/case
4140MTX	1.4	Blank	No	Bulk, 1000/case
4147MTX	1.4	Alphanumeric	No	10 Snap Racks of 96 tubes/case
4148MTX	1.4	Alphanumeric	Yes	10 Snap Racks of 96 tubes/case
4245MTX	1.4	Blank	No	10 Snap Racks of 96 tubes/case
4246MTX	1.4	Blank	Yes	10 Snap Racks of 96 tubes/case
4247MTX	1.4	Blank	No	10 Latch Racks of 96 tubes/case
4248MTX	1.4	Blank	Yes	10 Latch Racks of 96 tubes/case
4249MTX	1.4	Blank	No	10 Refill carriers of 96 tubes/case
4250MTX	1.4	Blank	Yes	10 Refill carriers of 96 tubes/case
4251MTX	1.4	Alphanumeric	No	10 Latch Racks of 96 tubes/case
4252MTX	1.4	Alphanumeric	Yes	10 Latch Racks of 96 tubes/case
4253MTX	1.4	Alphanumeric	No	10 Refill carriers of 96 tubes/case
4254MTX	1.4	Alphanumeric	Yes	10 Refill carriers of 96 tubes/case

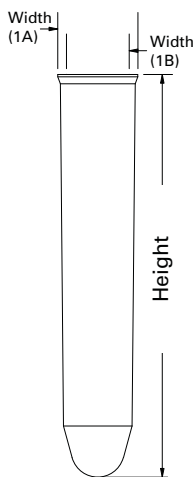

Figure 1

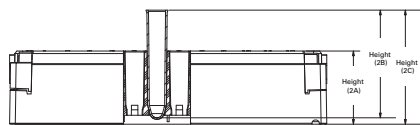

Figure 2

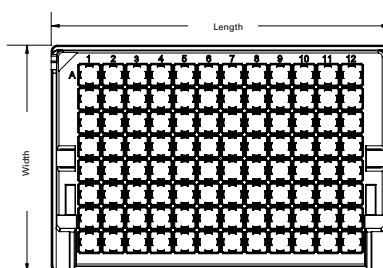

Figure 3

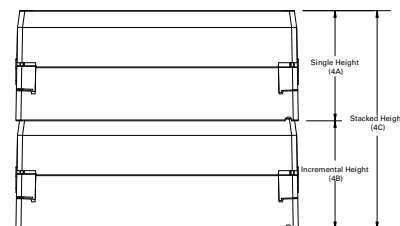

Figure 4

► Thermo Scientific Matrix SepraSeal and DuraSeal Capping Systems



DuraSeal caps are pre-split and pierceable



SepraSeals work in tandem with Thermo Scientific SuperSealer



Many color options to organize your samples

Matrix™ SepraSeal and DuraSeal tube sealing solutions complement the innovative line of Thermo Scientific Matrix 2D and non-2D coded storage tubes.

Available in a range of formats, colors, and sterility, there is a sealing option to meet a range of application and storage requirements.

details

Enhanced Materials

- Matrix SepraSeal and DuraSeal capping systems are made of an advanced thermoplastic elastomer that offers excellent chemical resistance and low vapor transmission rates, minimizing evaporation and water uptake in DMSO-based samples
- Elastomer ensures sealing performance will not degrade, even after multiple cap piercings

Sample Access Options

- Designed for storage down to -80°C, Matrix SepraSeal mats are available in sterile, non-sterile, solid, or pre-split, in a range of colors for quick visual sample identification
- Solid seals can be removed for sample access with the Matrix SepraSeal cap removal tool, or can be pierced once
- For applications involving repetitive sample access, a pre-split Matrix SepraSeal can be pierced by automated liquid handling equipment, requiring very little pressure, while maintaining seal integrity with self sealing closure
- For applications requiring storage in vapor phase liquid nitrogen, permanently installed DuraSeals are an ultra robust SepraSeal option – can also be used for repetitive piercing procedures
- The Matrix DuraSeals Pre-Split V-Shaped design reliably and accurately guides automated liquid handling needles into the same location over multiple piercings. Self-sealing design maintains sample integrity and prevents loss during storage

Application Flexibility

- The Matrix SepraSeal tube sealing solution offer the flexibility of individual tube capping while also providing the ability to apply 96 caps at once
- Supplied in mats of 96 caps each, sealing is secure and consistent every time when applied with the Thermo Scientific SuperSealer
- After the SuperSealer applies the mat, simply pull up the backing sheet to reveal 96 individually sealed tubes – for applications where multiple piercings are required
- The Matrix DuraSeal capping system is available in bulk or pre-installed in a wide array of our storage tubes

Specifications	
Cap Material	Virgin Class VI Medical-grade Thermoplastic Elastomer and Colorants
Backing Material	Styrene Butadiene
Compatibility	Thermo Scientific Matrix and most other 7 mm open-top tubes
Autoclavable	Caps: Yes Backing: No
Cap Temp Range	From 121°C to -80°C storage. DuraSeals can be stored as low as -180°C.

Matrix SeptraSeal and DuraSeal Capping Systems

Cat. No.	Seal Color	Compatible with Tube Volumes	Pre-Split	No. Per Case
4463MTX	Natural	0.5 mL; 0.75 mL, 1.4 mL		10 Mats of 96 / Case
4463BLU	Blue	0.5 mL; 0.75 mL, 1.4 mL		10 Mats of 96 / Case
4463GRE	Green	0.5 mL; 0.75 mL, 1.4 mL		10 Mats of 96 / Case
4463GRY	Gray	0.5 mL; 0.75 mL, 1.4 mL		10 Mats of 96 / Case
4463PIN	Pink	0.5 mL; 0.75 mL, 1.4 mL		10 Mats of 96 / Case
4463PUR	Purple	0.5 mL; 0.75 mL, 1.4 mL		10 Mats of 96 / Case
4463RED	Red	0.5 mL; 0.75 mL, 1.4 mL		10 Mats of 96 / Case
4463YEL	Yellow	0.5 mL; 0.75 mL, 1.4 mL		10 Mats of 96 / Case
Matrix SeptraSeal, Sterile				
4464MTX	Natural	0.5 mL; 0.75 mL, 1.4 mL		10 Mats of 96 / Case
4464BLU	Blue	0.5 mL; 0.75 mL, 1.4 mL		10 Mats of 96 / Case
4464GRE	Green	0.5 mL; 0.75 mL, 1.4 mL		10 Mats of 96 / Case
4464GRY	Gray	0.5 mL; 0.75 mL, 1.4 mL		10 Mats of 96 / Case
4464PIN	Pink	0.5 mL; 0.75 mL, 1.4 mL		10 Mats of 96 / Case
4464PUR	Purple	0.5 mL; 0.75 mL, 1.4 mL		10 Mats of 96 / Case
4464RED	Red	0.5 mL; 0.75 mL, 1.4 mL		10 Mats of 96 / Case
4464YEL	Yellow	0.5 mL; 0.75 mL, 1.4 mL		10 Mats of 96 / Case
Matrix SeptraSeal, Pre-Split				
4465MTX	Natural	0.5 mL; 0.75 mL, 1.4 mL	X	10 Mats of 96 / Case
4465BLU	Blue	0.5 mL; 0.75 mL, 1.4 mL	X	10 Mats of 96 / Case
4465GRE	Green	0.5 mL; 0.75 mL, 1.4 mL	X	10 Mats of 96 / Case
4465GRY	Gray	0.5 mL; 0.75 mL, 1.4 mL	X	10 Mats of 96 / Case
4465PIN	Pink	0.5 mL; 0.75 mL, 1.4 mL	X	10 Mats of 96 / Case
4465PUR	Purple	0.5 mL; 0.75 mL, 1.4 mL	X	10 Mats of 96 / Case
4465RED	Red	0.5 mL; 0.75 mL, 1.4 mL	X	10 Mats of 96 / Case
4465YEL	Yellow	0.5 mL; 0.75 mL, 1.4 mL	X	10 Mats of 96 / Case
Matrix SeptraSeal, Pre-Split, Sterile				
4466MTX	Natural	0.5 mL; 0.75 mL, 1.4 mL	X	10 Mats of 96 / Case
4466BLU	Blue	0.5 mL; 0.75 mL, 1.4 mL	X	10 Mats of 96 / Case
4466GRE	Green	0.5 mL; 0.75 mL, 1.4 mL	X	10 Mats of 96 / Case
4466GRY	Gray	0.5 mL; 0.75 mL, 1.4 mL	X	10 Mats of 96 / Case
4466PIN	Pink	0.5 mL; 0.75 mL, 1.4 mL	X	10 Mats of 96 / Case
4466PUR	Purple	0.5 mL; 0.75 mL, 1.4 mL	X	10 Mats of 96 / Case
4466RED	Red	0.5 mL; 0.75 mL, 1.4 mL	X	10 Mats of 96 / Case
4466YEL	Yellow	0.5 mL; 0.75 mL, 1.4 mL	X	10 Mats of 96 / Case
DuraSeal Caps, Bulk				
4490MTX	Natural	0.5 mL; 0.75 mL, 1.4 mL		500 / Case
Matrix SeptraSeal Cap Removal Tool				
4469MTX				1 / Case

► Thermo Scientific ID Scribe Labware Identifier



Unit includes dust cover for sample protection



Supplied with easy-to-use software



Uses standard laboratory markers

The ID Scribe Labware Identifier writes on tubes, vials and other laboratory materials to simply and legibly identify samples.

Save time identifying laboratory samples with permanent, legible writing. Economically replace handwritten samples or enhance 2D barcoded tubes with human-readable identification.

details

- **Legible, Repeatable Solution:** Whether storing for one day or retrieving samples years later, your sample identification will be legible throughout the life of the sample
- **Flexible Writing Range:** Imprints directly on curved and flat surfaces, and combined with the wide range of racks available, allows you to label nearly any type of labware
- **Time Saver:** Use pen colors for quick visual reference; each rack holds multiple pieces for fast, efficient labeling using Excel spreadsheets for data

Ordering Information: Racks are required for system operation and must be purchased separately.

Includes: ID Scribe unit, CD with software and electronic manual, 3 (EU, UK, US) country power cords, 5 pens (2 black, 1 red, 1 blue, 1 green), pen holder, printed manual

Warranty: 1 year in factory warranty; extended warranties available. Please contact Customer Service for details.

Compliance: RoHs.

Certifications: CE and CSA.

No label backing to dispose of means less waste in your laboratory.

Specifications		
	3200	3205
Dimensions, L x W x H, mm (in.)	387 x 457 x 229 (15.25 x 18 x 9)	381 x 1118 x 178 (15 x 44 x 7)
Weight, kg (lb.)	8 (18)	16 (36)
Power Supply, VAC, Hz, A	110-240, 50-60, 1.5	110-240, 50-60, 1.5
Speed	Varies by rack and labware type	Varies by rack and labware type
Capacity	1 rack of labware	4 racks of labware
Dust Cover/Lid Included	Yes	No
Racks Included	No	No
Computer Included	No	No
Software Included	Yes	Yes
Global Power Cords Included	Yes	Yes
Connection Method	Via supplied USB cable to PC or laptop	Via supplied USB cable to PC or laptop
Software Requirements	Windows™ XP, Vista™ or 7, Excel™ XP, 2003, 2007, 2010 running locally, one USB port	Windows XP,™ Vista or 7, Excel XP, 2003, 2007, 2010 running locally, one USB port

ID Scribe Labware Identifier

Cat. No.	Dimensions, L x W x H, mm (in.)	Capacity per Rack	Weight, kg (lb.)
3200 [†]	387 x 457 x 229 (15.25 x 18 x 9)	1	8 (18)
3205	381 x 1118 x 178 (15 x 44 x 7)	4	16 (36)

[†] Includes dust cover/lid

ID Scribe Racks

Cat. No.	For Use With	Compatible Labware Dimensions, W/O.D. x L, mm (in.)	Columns	Rows	Total Rack Capacity	Writing Surface	Case of
3300-11	1-2 mL Nunc CryoTubes, including CryoBank	12 x 55 (0.472 x 2.165)	3	7	21	Side	1
3301	1-1.4 mL 96-Way Tubes, Side Writing	7.5 x 56.5 (0.295 x 2.224)	3	12	36	Side	1
3302	1.5-2 mL Microcentrifuge Tubes, Side Writing	10.2 x 43.7 (0.402 x 1.720)	4	5	20	Side	1
3303-11	1.5-2 mL Microcentrifuge Tubes, Top Writing	10 x 11.8 (0.394 x 0.465)	7	6	42	Top	1
3304	15 mL Centrifuge Tubes, Side Writing	15.7 x n/a (0.618 x n/a)	2	5	10	Side	1
3305-11	Micropackaging Vials and Closures, Side Writing	10 x 50 (0.394 x 1.969)	3	7	21	Side	1
3306-11	3.6-4.5 mL Nunc CryoTubes, Side Writing	11.7 x 100 (0.461 x 3.937)	2	6	12	Side	1
3311-11	1.2 mL Nalgene Cryogenic Tubes, Side Writing	11.3 x 40.5 (0.445 x 1.594)	4	8	32	Side	1
3312	2 mL Nalgene Cryogenic Tubes	11.5 x 54.3 (0.453 x 2.138)	3	8	24	Side	1
3313-11	2 mL HPLC Vials	11.4 x 42.8 (0.449 x 1.685)	4	6	24	Side	1
3350-11	.5 mL Cryobank Tubes	8.4 x 36.3 (0.331 x 1.429)	4	11	44	Side	1
3351	.5-.75 mL 96-Way Tubes	7.4 x 41.5 (0.291 x 1.634)	4	12	48	Side	1
3352	0.5 mL Microcentrifuge Tubes	7.3 x 34.3 (0.287 x 1.350)	5	6	30	Side	1
3353	0.5 mL Microcentrifuge Tubes	7 x 12 (0.276 x 0.472)	8	6	48	Top	1
3354	50 mL Centrifuge Tubes	27.6 x n/a (1.087 x n/a)	2	3	6	Side	1
3355-11 [‡]	1-2 mL Nunc CryoTubes With Inserts	11 x 11 (0.433 x 0.433)	2	8	16	Top	1
3356	0.2 mL Microcentrifuge Tubes	5.3 x 25.5 (0.209 x 1.004)	6	7	42	Side	1
3357	0.2 mL Microcentrifuge Tubes	5.6 x 6.7 (0.220 x 0.264)	12	8	96	Top	1
3358 [‡]	Micropackaging Vials and Closures	10 x 11.8 (0.394 x 0.465)	7	6	42	Top	1
3359	PCR Strips, Top Writing	5.5 x n/a (0.217 x n/a)	8	1	8	Top	1
3360	~25 x 75 mm Slides	77 x 27 (3.301 x 1.063)	5	1	5	Top	1
3361	1.0 mL Cryobank Tubes	8.4 x 50 (0.331 x 1.969)	3	11	33	Side	1
3362	1.0 mL Nalgene System 100 Cryogenic Tubes	10 x 54.3 (0.394 x 2.138)	3	8	24	Side	1
3363	1.5 mL Nalgene System 100 Cryogenic Tubes	10.2 x 54.4 (0.402 x 2.142)	3	8	24	Side	1
3364	0.5 in. Microplate	85 x 133 (3.346 x 5.236)	1	1	1	Top	1
3365	IVF Straws, Side writing	3 x n/a (0.118 x n/a)	1	12	12	Side	1
3366 [‡]	1.0-1.2 mL Nalgene and Nunc CryoTube Caps With Inserts	12.3 x 12.4 (0.484 x 0.488)	8	2	16	Top	1

[‡] Requires cap inserts in place to write on

► Thermo Scientific Capit-All and Capit-All IS Screw Cap Tube Capper/Decapper



Cap or decap an entire rack of tubes in about ten seconds



Easily integrated into automated systems



Caps all tubes in a rack to the optimal torque level

Capit-All™ and Capit-All IS instruments cap and decap 24-, 48-, and 96-format Matrix and Nunc™ ScrewTop tubes with precision and ease.

Designed for benchtop or integrated use, the Capit-All instruments cap tubes to the optimal torque to maintain sample integrity and provide a hands free method of capping and decapping tubes quickly and easily.

details

Enhanced Productivity

- Increase throughput by capping and decapping an entire rack one at a time in approximately 10 seconds
- Automatically remove and replace caps on tubes of differing heights, even in the same rack, as well as tubes not properly seated in racks
- Completely replace manual capping and decapping methods
- Caps all tubes in a rack to the optimal torque level, maintaining sample integrity and preventing sample loss during storage

Superior Sample Protection

- Safety features ensure racks are loaded in the correct orientation and that caps are not cross-threaded or overtightened
- Drip tray prevents cross contamination of samples during addition and removal of tube racks
- Internal construction ensures debris is not introduced into uncapped tubes

Ease of Use

- The simple, four-button user interface enables laboratory personnel of any level to operate the instrument
- IS version is easily integrated into automated systems
- Easily maintained and able to process up to a million tubes before requiring preventative maintenance

Specifications	Capit All	Capit All IS
Speed	Approx. 10 seconds per rack	Approx. 15 seconds per rack
Operation	Hand operation via push buttons	Remotely via RS232; By computer via included drivers; Hand operation via push buttons
Power Supply, VAC, Hz	110-240, 50-60	110-240, 50-60
W x D x H, in. (mm)	12.9 x 14.2 x 22.0 (360 x 328 x 560)	27.6 x 13.4 x 22.0 (700 x 340 x 560)
Weight, lbs. (kg)	97 (45)	129 (58.5)

Capit-All and Capit-All IS Screw Cap Tube Capper/Decapper

Cat No	Description	Compatible Tubes	Channels
4111MAT	Capit-All Screw Top Tube Capper/ Decapper for 96 format Matrix tubes	Matrix ScrewTop 0.5 mL; 1.0 mL Tubes	96
4111MAT-IS	Automation Friendly Capit- All ScrewTop Tube Capper/Decapper for 96 format Matrix Tubes	Matrix ScrewTop 0.5 mL; 1.0 mL Tubes	96
4111NUN	Capit-All Screw Top tube Capper/ Decapper for 96 format Nunc tubes	Nunc Cryobank 0.5 mL; 1.0 mL Tubes	96
4111NUN-IS	Automation Friendly Capit-All Screw Top tube Capper/ Decapper for 96 format Nunc Tubes	Nunc Cryobank 0.5 mL; 1.0 mL Tubes	96
4114NUN	Capit-All Screw Top Tube Capper/ Decapper for 48 format Nunc Screw Top Tubes	Nunc Cryobank 2.0 mL; 5.0 mL Tubes	48
4114NUN-IS	Automation Friendly Capit-All Screw Top Tube Capper/ Decapper for 48 format Nunc Screw Top Tubes	Nunc Cryobank 2.0 mL; 5.0 mL Tubes	48
4112NUN	Capit-All Screw Top Tube Capper/ Decapper for 24 format Nunc Screw Top Tubes	Nunc Internally Threaded Cryotubes	24
4113NUN	Capit-All Screw Top Tube Capper/ Decapper for 24 format Nunc Screw Top Tubes	Nunc Externally Threaded Cryotubes	24
4113NAL	Capit-All Screw Top Tube Capper/ Decapper for 24 format Nalgene Screw Top Tubes	Nalgene Externally Threaded Cryotubes	24

Capit-All Screw Cap Tube Capper/Decapper Accessories

Cat No	Description
4090	ScrewTop Cap Tray Lifter for Capit-All (4111MAT) for use with 0.5 mL Matrix tubes
4091	ScrewTop Cap Tray Lifter for Capit-All (4111MAT) for use with 1.0 mL Matrix tubes
N12030	ScrewTop Cap Tray Lifter for Capit All (4111NUN) for use with 0.5 mL Nunc tubes
N12031	ScrewTop Cap Tray Lifter for Capit All (4111NUN) for use with 1.0 mL Nunc tubes



► Thermo Scientific 8-Channel Screw Cap Decapper



Decaps and caps tubes at the optimal torque for sealing

Our 8-Channel Screw Cap Capper/ Decapper allows ergonomic manual processing of a full rack of Thermo Scientific Matrix™ or Thermo Scientific Nunc™ tubes in less than one minute.

Designed to cap tubes to the optimal torque to maintain sample integrity and prevent sample loss during storage, the 8-channel Capper/Decapper is a practical addition to benchtop processing of ScrewTop storage tubes.

details

- Improves processing throughput of manual procedures with automated column-wise decapping and capping in just four seconds
- Ensures reproducibility by capping all tubes to the optimal torque level specified for the tube
- Lightweight, ergonomic and easy-to-use design can be used by anyone in the laboratory
- Long battery life and quick recharge time means the capper/decapper is virtually always available for use
- Stand allows easy storage of removed caps during sample processing steps
- Use with ScrewTop cap trays for application of fresh caps after sample processing



Capper/decapper side view

Capper/decapper front view

Specifications	
Speed	4 sec. to cap/decap 8 tubes
Power Supply	12V rechargeable battery, Input 100 to 240V, 50/60Hz, output 12V, 1.0A
Battery Life	Minimum 20 racks, cap and decap
Recharge Time (Fully Discharged), min.	90
L x W x H, cm (in.)	25.1 x 9.5 x 5.0 (9.87 x 3.76 x 2.0)
Net Weight, kg (lbs.)	0.44 (0.97)

8-Channel Screw Cap Decapper

Cat No	Description	Compatible Tubes
4105MAT	8-Channel Handheld Screw Cap Capper/ Decapper with Stand for Matrix-style Tubes	Matrix ScrewTop 0.5 mL; 1.0 mL Tubes
4105NUN	8-Channel Handheld Screw Cap Capper/ Decapper with Stand for Nunc-style Tubes	Nunc Cryobank 0.5 mL; 1.0 mL; 2.0 mL; 5.0 mL Tubes
4106	Capper/Decapper Stand	
4109	Capper/Decapper spare power supply	

► Thermo Scientific VisionMate High Speed 2D Barcode Reader



The VisionMate High Speed 2D Barcode Reader rapidly reads and decodes 2D barcodes of individual tubes through fully populated tube racks. Compatible with the line of Thermo Scientific 2D barcoded products, the VisionMate High Speed Reader's less than one second read time can increase throughput of manual or integrated workflows.

Compact, user-friendly reader provides exceptional flexibility with data export formats, tube type readability and tube layout options.

details

Speed and Versatility

- Intuitive software can be easily downloaded for manual use or remote control through TCP/IP connection.
- Scans a single 2D barcoded storage tube or entire tube rack in less than one second
- Robust optics and compact, integration-friendly design are ideal for high-throughput use

Enhanced Tube Readability

- Configured for all Thermo Scientific 2D barcoded tubes and user configurable for other 2D tube formats
- Integration of linear 1D barcode reader allows integration of individual tube and rack barcode data

Simple Operation

- Connect to your computer via a single USB port and, despite which way the tube rack is placed, the computer automatically adjusts orientation and correctly aligns codes with well positions
- Quickly and easily download software and upgrades from www.thermoscientific.com
- Connects to PC via a single USB port for easy installation

Superior Sample Protection

- Operates down to -40°C, enabling barcode reading in cold rooms and low temperature liquid stores to preserve sample integrity
- Sealed unit prevents frost and condensation which allows reading frozen tubes at ambient temperatures

Data File Flexibility

- Easily integrated into LIMS, databases or tracking systems
- User-defined code types and lengths indicate incorrect codes and limit access by user profile

Specifications	
Speed	< 1 second/rack
Decoding Capacity	1 rack
Data Transfer Method	Data transfer to comma-delimited linear and columnar ASCII text files; ActiveX controls
D x W x H, in. (cm)	8 x 8.75 x 7.25 (20.5 x 22.5 x 18.5)
Weight, kg (lbs.)	2.27 (5)
Power Supply, VAC, Hz	115-240, 50-60
Supported Barcode	Any Thermo Scientific Matrix 2D Barcoded Storage Tube in 8 x 12 or 4 x 6 format as well as virtually any other 2D barcode in similar formats
Computer Requirements	Microsoft™ Windows™ controller PC

VisionMate High Speed 2D Barcode Reader

Cat. No.	Description
AB1850	VisionMate High Speed 2D Barcode Reader
AB1860	VisionMate High Speed Linear Barcode Reader Accessory

► Thermo Scientific VisionMate Wireless 2D Barcode Reader



The VisionMate Wireless 2D Barcode Reader decodes both individual 2D barcodes and linear barcodes.

Integrated Bluetooth technology allows wireless operation and barcode reading flexibility in the lab, cold room or in-field applications. Seamlessly transmit data to laptop, PC, or PDA device.

details

- Hold a Matrix 2D Barcoded Storage Tube over the VisionMate Wireless' scanning window and the code is decoded and imported instantly into any application, including spreadsheets, databases and LIMS
- Easily scan and record linear (1D) barcodes into your applications
- Enables barcode reading in your cold room, in the field or across the laboratory via Bluetooth technology

Effortless Operation

- The VisionMate's flat bottom profile allows hands-free scanning, yet at only 13.5 ounces (383 grams) the unit can be used by anyone decoding linear or 2D barcodes

Specifications	
W x D x H, in. (cm)	1.68 x 7.4 x 2.28 (18.8 x 4.3 x 5.8)
Weight, g (oz.)	383 (13.5)
Battery Run Time	8 hours of continuous run time
Charging Time	Approximately 6 hours
Battery Indicator Life	Green: 100-50% charged Amber: 50-20% charged
Charging Connection	Via supplied USB port connection
Computer Requirements	Microsoft™ Windows™ controller PC

VisionMate Wireless 2D Barcode Reader

Cat. No.	Description
3122MTX	VisionMate Wireless 2D Barcode Reader

► Thermo Scientific VisionTracker Storage Tracking Database Software



VisionTracker™ Storage Tracking Database Software provides an intuitive and secure database for the storage of your precious sample data and corresponding locations.

Whether storing in linear barcoded cryotubes, 2D barcoded tubes, or other storage vessels, VisionTracker can help to easily organize and track your samples. VisionTracker is ideal for use with the VisionMate 2D reader portfolio for seamless integration of linear or 2D barcode data.

Specifications	
Maximum Sample Storage Capacity	16,000,000 tube samples*
Audit Trail	Tracks all sample data; date and time-stamped
Search Criteria	All fields searchable
User Levels	Administrator and User; password protected
Import File Formats	Excel and Open Office, locally-installed compatibility only
Operating System Compatibility	Microsoft® Windows – XP, Vista or Windows 7; Excel XP, 2003, 2007, 2010 running locally; one USB port

** Search time may increase with larger numbers of samples stored*

VisionTracker Storage Tracking Database Software

Cat. No.	Description
3220	VisionTracker Storage Tracking Database Software

► Thermo Scientific VisionMate SR Single Rack 2D Barcode Reader



The VisionMate™ SR 2D Barcode Reader decodes a full rack of barcoded storage tubes in less than ten seconds.

This compact, user-friendly reader provides exceptional flexibility with data export formats, tube type readability, and tube layout options.

details

- Control through versatile on-screen software or remotely through TCP/IP connection.
- Speed: scans a full tube rack in less than ten seconds
- Simple operation: simply follow the instructions during software installation and connect the reader to a computer via USB port
- Flexible: integrates easily with LIMS, existing databases or tracking systems
- Space-conscious: small footprint and compact profile save valuable benchtop space



Specifications	
Dimensions (W x D x H)	280 mm (11.0 in.) x 160 mm (6.3 in.) x 55 mm (2.2 in.)
Weight kg (lbs.)	0.8 (1.76)
Power Supply	110-240 V, 50-60 Hz
Speed	4 seconds/rack
Decoding Capacity	1 rack of any tube format, including 384
Supported Barcode Type	Any Thermo Scientific 2D Barcoded Storage tube, plus any other standard 2D Data Matrix-coded storage tube
Computer Requirements	1 GB RAM PC with Microsoft® Windows® 2000, Windows XP or higher (including Windows Vista®); 2 GHz Processor
Connection Method	Via supplied USB cable to internal USB2 port (external USB hubs not recommended)
Data Transfer Method	Microsoft Excel file; Text file (comma delimited, columnar file); COM Port; Virtual COM Port; X mL file; TCP/IP; ActiveX® and ODBC

VisionMate SR Single Rack 2D Barcode Reader

Cat No	Description
3115	VisionMate SR 2D Barcode Reader

▶ Thermo Scientific VisionMate ST Single-Tube 2D Barcode Reader



The VisionMate™ ST Barcode Reader is a compact single tube reader used for instant scanning of individual 2D barcoded tubes into any file or database application.

Simple plug-and-play installation via automatically installed USB port allows simple and easy set up.

details

- Simple to install and use
- Instant read time
- For individual sample retrieval
- Export flexibility: via comma-separated variable file, Microsoft® Excel™, X mL, COM port, ODBC or TCP socket

Specifications	
Dimensions (W x D x H)	111 mm (4.37 in.) x 87 mm (3.43 in.) x 70 mm (2.76 in.)
Weight kg (lbs.)	0.8 (1.76)
USB Operating Temperature	4°C to 30°C
Supported Barcode Type	Any Thermo Scientific 2D Barcoded Storage Tube as well as virtually any other tube with high contrast 2D codes
Computer Requirements	128 MB RAM PC with Intel® Pentium® 3 or Microsoft Windows 98 or higher (including Windows Vista®) and 1 USB port

VisionMate ST Single-Tube 2D Barcode Reader

Cat No	Description
3125	VisionMate ST 2D Barcode Reader

► Labware Chemical Resistance Table

Interpretation of Chemical Resistance

The Chemical Resistance Chart that follows is a general guide only. Because so many factors can affect the chemical resistance of a given product, you should test under your own conditions.

Effects of Chemicals on Plastics

Chemicals can affect the strength, flexibility, surface appearance, color, dimensions or weight of plastics. The basic modes of interaction which cause these changes are: (1) chemical attack on the polymer chain, with resultant reduction in physical properties, including oxidation; reaction of functional groups in or on the chain; and depolymerization; (2) physical change, including absorption of solvents, resulting in softening and swelling of the plastic; permeation of solvent through the plastic; dissolution in a solvent; and (3) stress cracking from the interaction of a "stress cracking agent" with internal or external stresses.

Mixing and/or dilution of certain chemicals can be potentially dangerous.

The reactive combination of different chemicals or compounds of two or more classes may cause an undesirable chemical effect or result in an increased temperature, which can affect chemical resistance (as temperature increases, resistance to attack decreases). Other factors affecting chemical resistance include pressure and internal or external stresses (e.g. centrifugation), length of exposure, and concentration of the chemical.

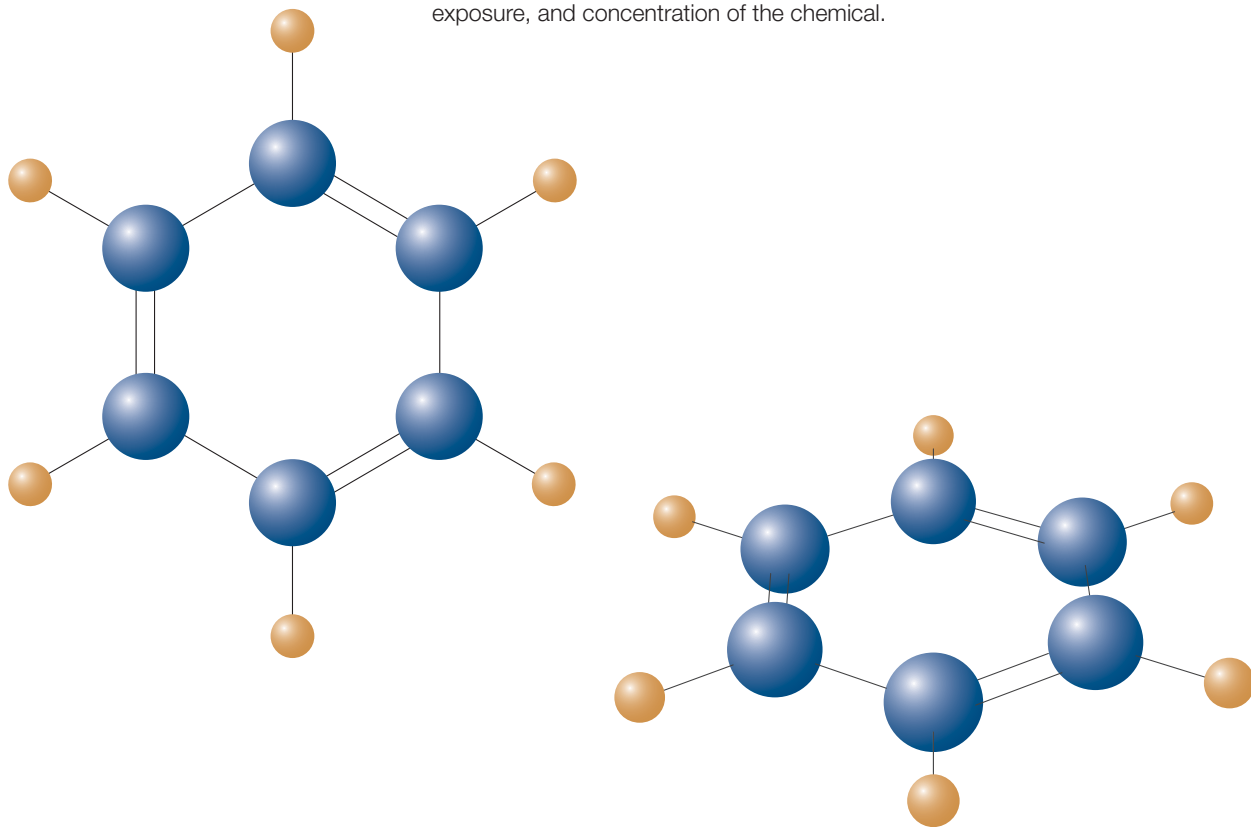

Environmental Stress Cracking

Environmental stress cracking is the failure of a plastic material in the presence of certain types of chemicals.

This failure is not a result of chemical attack. Simultaneous presence of three factors causes stress cracking: tensile stress, a stress cracking agent and the inherent susceptibility of the plastic to stress cracking.

Common stress cracking agents are detergents, surface active chemicals, lubricants, oils, ultra-pure water and plating additives such as brighteners and wetting agents. Relatively small concentrations of stress cracking agent may be sufficient to cause cracking.

Mixing and/or dilution of certain chemicals may result in reactions which produce heat, which can cause product failure.

Pre-test your specific usage and always follow correct lab safety procedures.

Caution: Do not store strong oxidizing agents in plastic labware except that made of Teflon® FEP or PFA. Prolonged exposure can cause the material to become brittle and fail.

While prolonged storage may not be intended at time of filling, a forgotten container will fail in time and result in leakage of contents. Do not place any plastic labware into a flame.

Resin Codes	
ECTFE	Halar® ECTFE (ethylene-chlorotrifluoroethylene copolymer)
ETFE	Tefzel ETFE (ethylene-tetrafluoroethylene)
FEP	Teflon® FEP (fluorinated ethylene propylene)
HDPE	high-density polyethylene
FLPE	fluorinated polyethylene
LDPE	low-density polyethylene
PC	polycarbonate
PEI	polyetherimide
PET	polyethylene terephthalate
PETG	polyethylene terephthalate copolymer
PFA	Teflon® PFA (polyfluoroalkoxy)
PMMA	polymethyl methacrylate (acrylic)
PMP	polymethylpentene
PP	polypropylene
PPCO	polypropylene copolymer
PS	polystyrene
PSF	polysulfone
RESMER	RESMER manufacturing technology
SAN	styrene acrylonitrile
TFE	Teflon® TFE (tetrafluoroethylene)
TMX	Thermanox
PMX	Permanox

Teflon® is a registered trademark of DuPont used under license by Nalge Nunc International Corporation

Halar® is a registered trademark of Solvay Solexis

PPCO has replaced polyallomer (PA) in all products

► Labware Chemical Resistance Table, continued

Chemical, Concentration	CAS #	EC Number	M.W.	Labware Olefin Polymers												Labware Fluoropolymers			
				LDPE		HDPE		PPP		PPCO		PMP		FLPE		FEP		TFE/PTFE	
				20	50	20	50	20	50	20	50	20	50	20	50	20	50	20	50
1-(4-Chlorophenyl)ethanone, pure	99-91-2	202-800-7	154.60	E	E	E	E	G	F	E	E	E	E	E	E	E	E	E	E
1,3-Butadiene, pure	106-99-0	203-450-8	54.09	N	N	F	N	N	N	N	N	N	N	G	F	E	E	E	E
1,4-Dioxane, pure	123-91-1	204-661-8	88.11	G	F	G	G	F	N	G	F	F	N	E	E	E	E	E	E
1:3 Mixture Of Nitric And Hydrochloric Acids, pure	8007-56-5		N/A	N	N	N	N	N	N	N	N	N	N	N	N	E	E	E	E
1-Pentanol, pure	71-41-0	200-752-1	88.15	E	E	E	E	E	G	E	E	G	F	E	E	E	E	E	E
1-Phenylethanone, pure	98-86-2	202-708-7	120.15	N	N	F	F	G	F	F	N	G	N	G	G	E	E	E	E
1-Undecanol, pure	112-42-5	203-970-5	172.31	E	F	E	G	E	G	E	G	E	G	E	E	E	E	E	E
2,2,4-Trimethylpentane, pure	540-84-1	208-759-1	114.23	F	N	F	N	F	N	F	N	F	N	G	F	E	E	E	E
2,2'-Oxybispropane, pure	108-20-3	203-560-6	102.18	N	N	F	N	N	N	N	N	N	N	E	G	E	E	E	E
2,4,6-Trinitrophenol, pure	88-89-1	201-865-9	229.11	N	N	N	N	N	N	N	N	E	E	N	N	E	E	E	E
2-Hydroxy-1,2,3-Propanetricarboxylic Acid Tributyl Ester, pure	77-94-1	201-071-2	360.45	G	F	E	G	G	F	G	F	G	F	E	E	E	E	E	E
2-Hydroxybenzaldehyde, pure	90-02-8	201-961-0	122.12	E	G	E	E	E	G	E	G	E	G	E	E	E	E	E	E
2-Isopropoxypropane, pure	108-20-3	203-560-6	102.18	N	N	F	N	N	N	N	N	N	N	E	G	E	E	E	E
2-Methoxyethanol, pure	109-86-4	203-713-7	76.10	E	G	E	E	E	G	E	E	E	E	E	E	E	E	E	E
2-Methoxyethyl Oleate, pure	111-10-4	203-834-5	340.54	E	G	E	E	E	G	E	G	E	G	E	E	E	E	E	E
2-Propanol, pure	67-63-0	200-661-7	60.10	E	E	E	E	E	E	E	E	E	E	E	E	E	E	E	E
2-Propanone, pure	67-64-1	200-662-2	58.08	G	N	N	N	F	N	N	N	E	E	F	F	E	E	E	E
2-Propenenitrile, pure	107-13-1	203-466-5	53.06	E	E	E	E	F	N	F	N	F	N	E	E	E	E	E	E
3-Phenyl-2-propenal, pure	104-55-2	203-213-9	132.18	N	N	G	N	N	N	N	N	N	N	G	G	F	F	G	G
4'-Chloroacetophenone, pure	99-91-2	202-800-7	154.60	E	E	E	E	G	F	E	E	E	E	E	E	E	E	E	E
Acetaldehyde, pure	75-07-0	200-836-8	44.05	G	N	G	F	G	N	G	N	G	N	E	G	E	E	E	E
Acetic Acid Benzyl Ester, pure	140-11-4	205-399-7	150.18	E	G	E	E	E	G	E	G	E	G	E	E	E	E	E	E
Acetic Acid Phenylmethyl Ester, pure	140-11-4	205-399-7	150.18	E	G	E	E	E	G	E	G	E	G	E	E	E	E	E	E
Acetic Anhydride, pure	108-24-7	203-564-8	102.09	N	N	F	F	G	F	G	F	E	G	F	F	E	E	E	E
Acetone, pure	67-64-1	200-662-2	58.08	G	N	F	N	F	N	N	N	E	E	E	G	E	E	E	E
Acetonitrile, pure	75-05-8	200-835-2	41.05	E	E	E	E	E	G	F	N	F	N	E	E	E	E	E	E
Acetophenone, pure	98-86-2	202-708-7	120.15	N	N	F	F	G	F	F	N	G	N	G	G	E	E	E	E
Acrylonitrile, pure	107-13-1	203-466-5	53.06	E	E	E	E	F	N	F	N	F	N	E	E	E	E	E	E
Adipic Acid, pure	124-04-9	204-673-3	146.14	E	G	E	E	E	E	E	E	E	E	E	E	E	E	E	E
Alanine, pure	56-41-7	200-273-8	89.09	E	E	E	E	E	E	E	E	E	E	E	E	E	E	E	E
Allyl Alcohol, pure	107-18-6	203-470-7	58.08	E	E	E	E	E	E	E	E	E	E	G	E	E	E	E	E
Aluminum Chloride, pure	7446-70-0	231-208-1	133.34	E	E	E	E	E	E	E	E	E	E	E	E	E	E	E	E
Aluminum Hydrate, pure	21645-51-2	244-492-7	78.00	E	G	E	E	E	G	E	E	E	G	E	E	E	E	E	E
Aluminum Hydroxide, pure	21645-51-2	244-492-7	78.00	E	G	E	E	E	G	E	E	E	G	E	E	E	E	E	E
Aluminum Salts, pure	N/A		N/A	E	E	E	E	E	E	E	E	E	E	E	E	E	E	E	E
Aluminum Trihydrate, pure	21645-51-2	244-492-7	78.00	E	G	E	E	E	G	E	E	E	G	E	E	E	E	E	E
Amino Acids, pure	N/A		N/A	E	E	E	E	E	E	E	E	E	E	E	E	E	E	E	E
Ammonia, pure	7664-41-7	231-635-3	17.03	E	E	E	E	E	E	E	E	E	E	F	F	E	E	E	E
Ammonium Chloride, pure	12125-02-9	235-186-4	53.49	E	E	E	E	E	E	E	E	E	E	E	E	E	E	E	E

E No damage after 30 days of constant exposure.

F Some effect after 7 days of constant exposure.

G Little or no damage after 30 days of constant exposure.

N Immediate damage may occur. Not recommended for continuous use.